

# Tesla Regen, Brakes and Sudden Acceleration

by

Ronald A. Belt  
Plymouth, MN 55447

1 June 2020

**Abstract:** EDR log data from a Tesla sudden acceleration incident is presented. To explain the EDR data, the operation of Tesla’s drive motor control system and braking system are examined. As expected, friction braking and regen are completely separate with no blending. The braking system, however, includes several vehicle stability control functions that have a profound effect on regen operation in the presence of wheel slip, such as stopping regen when going over bumps and while turning corners. One of these slip control functions can cause the drive motor to speed up if regen is causing slip in the rear drive wheels that can lead to an oversteer or understeer. This same slip control function can be misled by a defective brake light switch to confuse a brake-induced deceleration for a regen-induced deceleration, in which case the harder a driver presses on the brake pedal, the larger a positive motor torque is produced. This is believed to be the cause of sudden acceleration in over 70% of Tesla vehicles.

## I. Introduction

EDR data from a Tesla M3 sudden acceleration incident reveals several inconsistencies between the EDR data, the driver’s testimony, and Tesla’s own analysis of the log data of the incident. To explain these inconsistencies, the designs of Tesla’s drive motor control system and braking system were examined. The resulting explanation revealed that the cause of the sudden acceleration lies in the vehicle’s braking system and how it interacts with the regen system.

## II. EDR data

The EDR data for this incident will now be described. The incident involved a driver entering the driveway of her home with the intent of parking in the attached garage. As the vehicle neared the end of a 90° right-hand turn into the driveway, the driver had her right foot hovering over the brake pedal in preparation for the garage door to fully open. Suddenly, the vehicle’s drive motor revved up, causing the vehicle to leap forward and veer to the left. Simultaneously, she pressed the brake pedal, but was unable to stop the vehicle in time before it struck a brick wall between the two garage doors, causing minor damage to the right front corner of her vehicle. The vehicle was a 2019 Tesla M3 with a single rear drive motor. The vehicle was in the HOLD mode with STANDARD regen throughout the incident. (Figure 1).

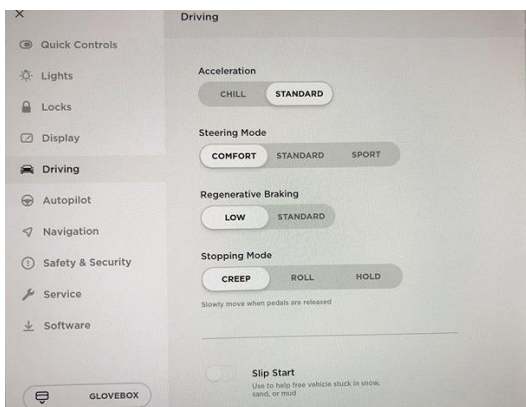

Fig 1. Model 3 control panel showing options for driving mode and regen braking

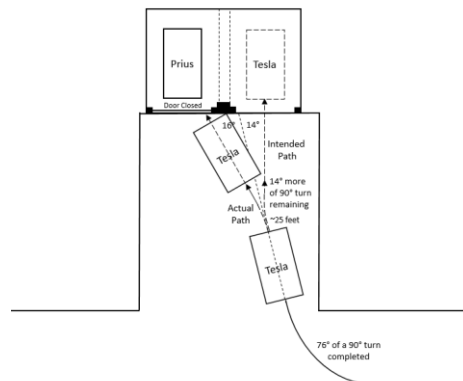

Fig 2. Vehicle path for the incident as inferred from the EDR data

Figure 2 shows the vehicle path during the incident. The street and driveway were both flat and on the same horizontal level. Figure 3 shows the EDR data for the pre-crash values of the accelerator pedal (%), rear motor speed (RPM), and vehicle speed (MPH). The accelerator pedal data shows that a value of 80% was reached one second prior to the crash. The vehicle speed data shows that the speed changed from 6 MPH before the crash to 14 MPH at the time of the crash. These alone might suggest that the driver pressed on the accelerator pedal to cause the crash. However, the pre-crash accelerometer data tell a different story.

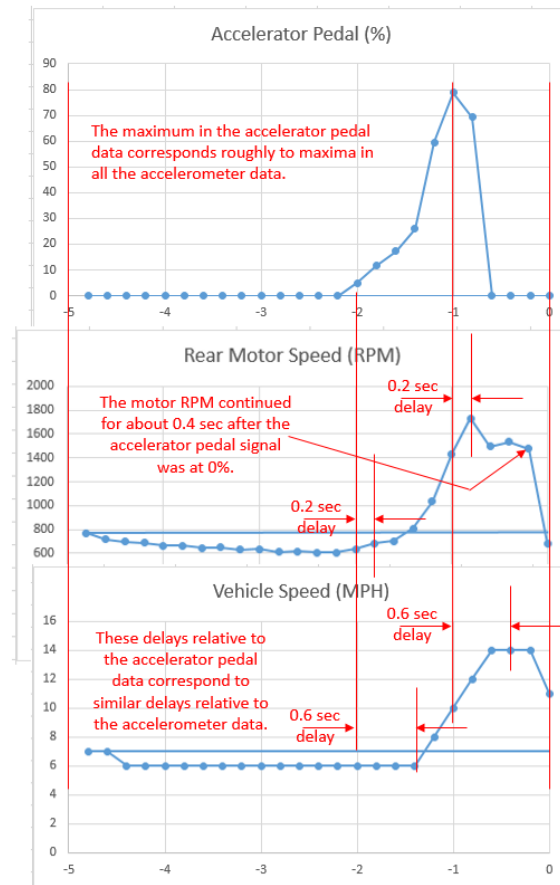

Figure 3. EDR data showing pre-crash values of accelerator pedal (%), rear motor speed (RPM), and vehicle speed (MPH)

Figure 4 shows the pre-crash accelerometer data. The longitudinal accelerometer data show that the vehicle had a rapid deceleration of  $-0.5\text{ g}$ 's from  $+0.1\text{ g}$  to  $-0.4\text{ g}$  one second before the crash. Since the Model 3's regeneration is limited to  $-0.2\text{ g}$ 's (increased to  $-0.3\text{ g}$ 's by software update 2018.42 v9 on October 25, 2018), this higher  $-0.5\text{ g}$  deceleration could not have been caused by the vehicle's regen system. Instead, it can only have been caused by the vehicle's braking system. This conclusion is supported by the high resolution log data described by Tesla which shows that the brakes were applied even though the EDR data says they were not (Fig 5). Therefore, the driver was pressing on the brake pedal at the time the drive motor revved up, exactly as she described.

Comparison of the accelerator pedal data to the longitudinal acceleration data shows that the increase and decrease in the accelerator pedal data are coincident with the decrease and increase in the longitudinal acceleration data, which is determined by the depression of the brake pedal. This suggests the possibility that the accelerator pedal may have been pressed at

the same time as the brake pedal. However, Tesla has often stated in public that if this happens the brake pedal will always win, implying that a brake pedal override function exists in all Tesla vehicles that will cancel the accelerator command.<sup>1, 2</sup> The brake pedal is also higher than the accelerator pedal, preventing the accelerator pedal from being pressed to 88% while also pressing the brake pedal with the same foot. Therefore, the accelerator pedal in this case could not have been pressed at the same time as the brake pedal. So, what could have caused the drive motor to rev up if the driver was pressing on the brake pedal and not on the accelerator pedal?

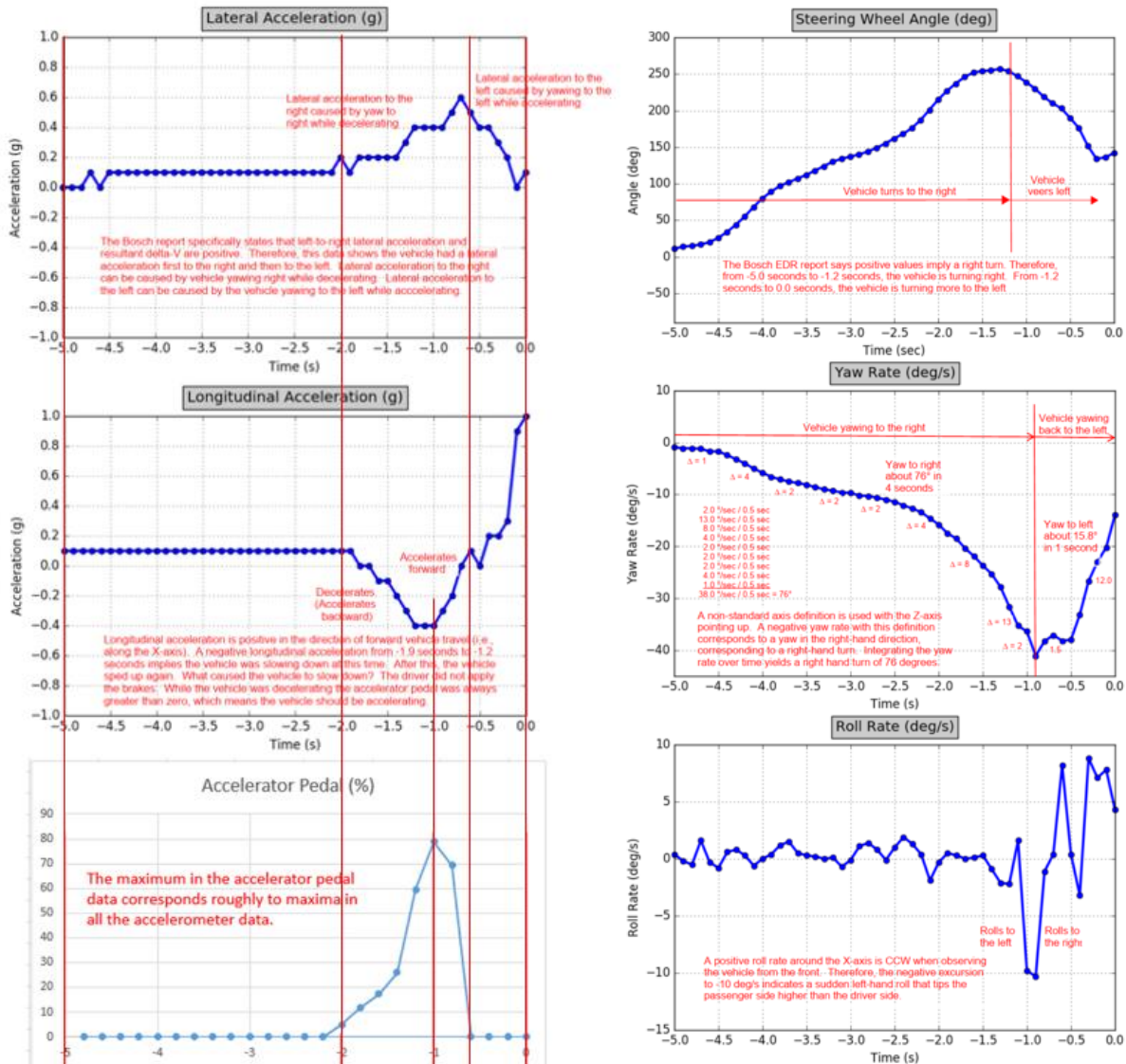

Figure 4. Pre-crash accelerometer data. An ISO 8855 coordinate system is used in which the longitudinal x-axis points forward, the y-axis points to the driver's left, and the z-axis points up. The steering wheel angle is positive when turned to the right.

The longitudinal acceleration data in Figure 4 also shows no evidence that regen is occurring as the vehicle is turning into the driveway before the drive motor revs up. This observation is supported by the vehicle speed data of Figure 3, which shows that the vehicle speed remains constant at 6 MPH before the drive motor revs up. Yet, the driver maintains that the vehicle was in the HOLD mode with STANDARD regen throughout the incident. If the driver is correct, then why isn't regen apparent in the data of these two sensors?

More inconsistencies become apparent if we compare the accelerometer data while aligned in time, as shown in Figure 6. Both the steering wheel data and the yaw rate data agree with each other and show that the vehicle was turning to the right into the driveway. At about 76° into the 90° turn, as the drive motor revs up to cause the vehicle to accelerator forward, both the steering wheel data and the yaw rate data change direction, indicating a veer to the left. The acceleration in the forward direction appears to be causing the veer to the left. This change of direction in the yaw data reconciles the difference between the driver's testimony and the EDR data and Tesla's letter as shown in table of Figure 5.

Driver Testimony	Tesla Letter	EDR Data
Accel pedal not pressed	Accel pedal to 88%	Accel pedal to 79%
Damage to right front implies vehicle turned to left	Steering wheel turned to right	Steering wheel turned to right
Brakes Applied	Brakes Applied	Brakes Not Applied
	ABS Engaged	ABS not Engaged

Figure 5. Comparison of the driver's testimony with the EDR data and a Tesla letter describing the high resolution log data.

A closer look at the steering wheel angle data and the yaw rate data reveals that the yaw rate is still increasing while the steering wheel angle is leveling off or even decreasing. This suggests that front wheel slip is occurring to cause an oversteer condition, which could activate the

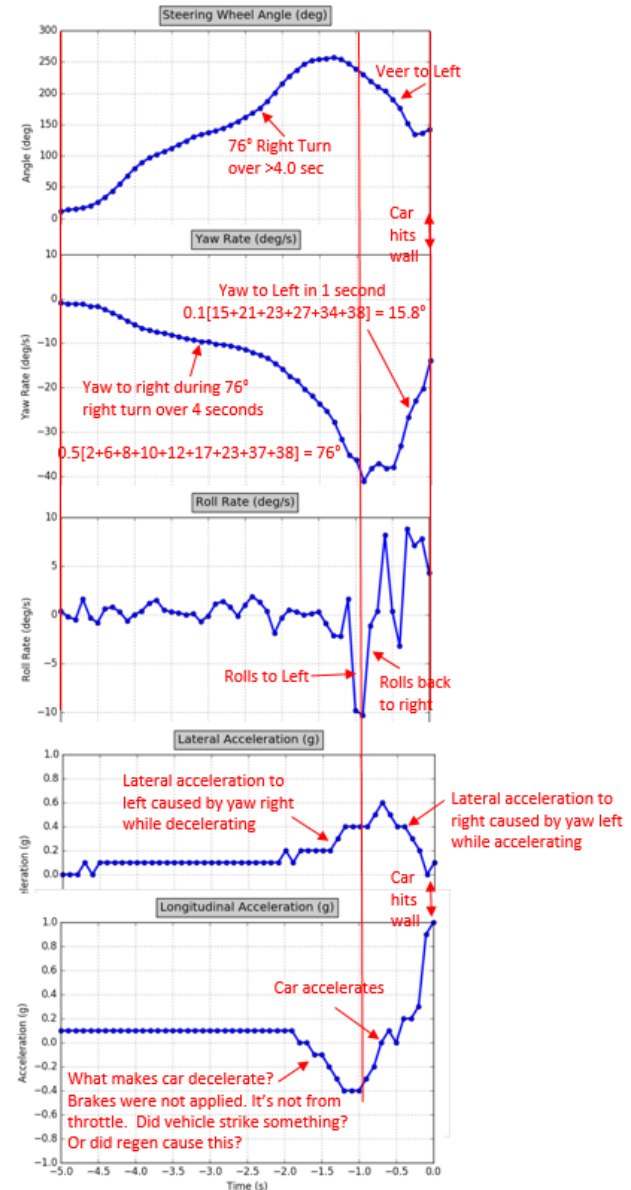

Figure 6. Accelerometer plots aligned in time show that the peaks roughly align at -1.0 seconds

vehicle's stability control system. The normal response of a vehicle stability control system to an oversteer condition is to brake the outside front wheel to cause a yaw moment in the direction opposite to the oversteer direction. In this case, during an oversteer to the right, the left front wheel would be braked, causing the vehicle to yaw to the left. This is exactly what is observed. This appears to explain the driver's testimony that the vehicle "turned to the left" to cause damage to the right front corner of her vehicle.

The lateral acceleration data also show an increase and decrease in the lateral acceleration that corresponds to the increase and decrease in the longitudinal acceleration, as one would expect when accelerating forward while turning to the right. The roll data also shows a roll to the left and then back to the right in agreement with the lateral acceleration data. The EDR data taken together show that a sequence of events occurs that begins with a 90° turn to the right with no regen occurring, followed by the brakes being applied, during which the drive motor speeds up to cause a forward acceleration that produces an oversteer situation that activates the electronic stabilization system, which brakes the front left wheel to cause the vehicle to veer to the left.

It is interesting that the vehicle's longitudinal (forward) acceleration continues to increase until the vehicle crashes into the garage, even though the accelerator pedal reading goes to zero over a half second before the crash. One would expect that the vehicle's velocity would remain constant or even decrease after the accelerator pedal reading goes to zero, but the longitudinal acceleration should cease, or even go negative with regen, when the accelerator pedal is released. Also, the rear motor speed data show that the drive motor speed remains high even after the accelerator pedal is released. This suggests that the drive motor is still producing torque to accelerate the vehicle in the forward direction at the time of the crash, which is over a half second after the accelerator pedal is released. How can this happen?

Finally, the EDR data show that the brakes were not applied during the incident while the driver maintains that they were. However, the longitudinal accelerometer data and Tesla's letter based on the high resolution log data verify that the brakes were applied in support of the driver's testimony. Likewise, the EDR data show that the ABS system did not engage while both the accelerometer data and Tesla's letter based on the high resolution log data verifies that the ABS system did engage.

In summary, the EDR data taken together show that a sequence of events takes place that begins with a 90° turn to the right with no regen occurring, followed by the brakes being applied, during which the drive motor speeds up to cause a forward acceleration that produces an oversteer situation that activates the electronic stabilization system, which brakes the front left wheel to cause the vehicle to veer to the left. However, we are left with a number of questions as to how this could happen:

1. Why does regen appear to be absent in the vehicle velocity data and the longitudinal acceleration data during the turn when the driver claims that the vehicle was in the HOLD mode at the time and the driver was not pressing on the accelerator pedal?
2. Why does the single rear drive motor speed increase at exactly the same time as the brakes are being applied?
3. If the driver had her foot on the brake pedal to cause the -0.5 g longitudinal acceleration, then how could she also have pressed on the accelerator pedal at the same time to cause the drive motor to speed up? Tesla has stated many times in writing that when the accelerator pedal and the brake pedal are pressed at the same time, the brake pedal always wins. Therefore, the speeding up of the drive motor cannot be due to the driver pressing on the accelerator pedal, and must have been caused by the vehicle itself.
4. Why does the drive motor speed remain high and the vehicle continue to accelerate forward even after the accelerator pedal reading has decreased back to zero?

5. Why did the vehicle steer to the left as the motor speed increases, even though the driver was making a right hand turn?
6. Why does the EDR data show that the brake pedal was not pressed even though the driver maintains that she did press the brake pedal and even though Tesla's letter based on the high resolution log data agrees with the driver?
7. If the driver never pressed the accelerator pedal, then why does the EDR data show that the accelerator pedal was pressed?
8. Why does the EDR data show that the ABS system did not engage when both the accelerometer data and Tesla's letter based on the high resolution log data verify that the ABS system did engage?

To seek answers to these questions, the designs of Tesla's drive motor control system and braking system were examined.

### III. Tesla Drive Motor Control System

For the benefit of readers not familiar with Tesla's one pedal driving (OPD) system, we will start by describing how this system operates. This system allows control over both acceleration and regen braking by varying the depression of the accelerator pedal. During regen braking, deceleration of the vehicle causes the vehicle's drive motor to act as a generator that recharges the drive battery. This recharging is essential to obtaining the high number of miles on a single battery charge that Tesla claims and drivers require. If regen is controlled only by the brake pedal, then such high mileage would not be possible because infrequent braking events would not charge the battery often enough unless the driver rides the brake pedal, which is tiring to the driver and hazardous to other vehicles.

Figure 7 shows how Tesla's one pedal driving system operates. When the accelerator pedal is pressed to the floor the driver gets 100% acceleration. As the accelerator pedal is eased up, the driver gets less acceleration. As the accelerator pedal is eased up further, eventually the

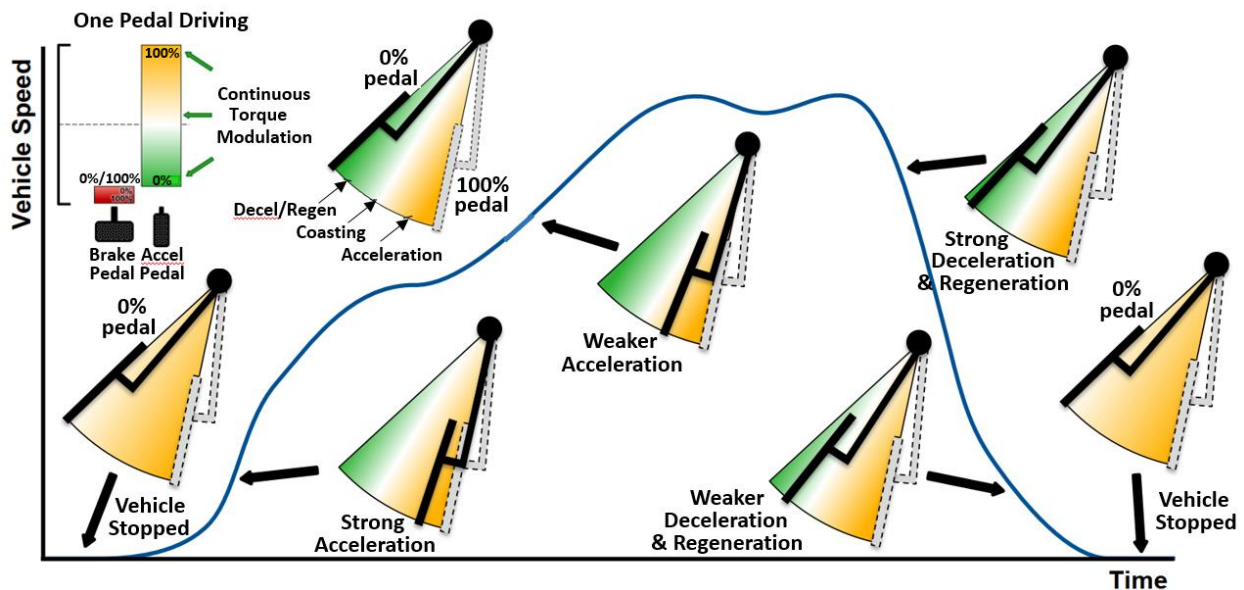

Figure 7. Tesla's one pedal driving system uses the accelerator pedal for both accelerating and braking.<sup>3</sup>

vehicle acceleration ceases and turns into a mild deceleration with a small amount of battery charging. This deceleration with battery charging is called regen. It feels to the driver like a combustion engine vehicle with a stick shift while decelerating in second gear. In between the

acceleration and deceleration points is a “sweet spot” that allows vehicle coasting. When the accelerator pedal is fully released, the driver gets the maximum deceleration with a maximum amount of battery charging, or maximum regen. The deceleration value with maximum regen is about 0.2 g’s on older Tesla’s and 0.3 g’s on newer Tesla’s. With 0.3 g’s the deceleration level feels like a combustion engine vehicle with a stick shift while decelerating in first gear. The feature of one pedal driving that all Tesla drivers appreciate is that torque can be modulated continuously between maximum positive torque and negative braking torque while keeping one’s foot on the accelerator pedal. The only time that the driver needs to press the brake pedal is when he wants to come to a complete stop or when he needs to do emergency braking at a level higher than 0.3 g’s.

Figure 8 shows the first step in Tesla’s drive motor control system. In this step a pedal map translates the accelerator pedal position set by the driver into a requested motor torque value. The pedal map consists of a two-dimensional look-up table accessed by the accelerator pedal position signal. Torque values for vehicle velocities in between velocities on the horizontal axis are obtained by interpolating between torque values for vehicle velocities that are in the map. The accelerator pedal position signal is an 8-bit sign-magnitude integer obtained by calculation from the dual accelerator pedal position sensors. The torque values are 8-bit sign-magnitude integers in the Tesla Model 3 and 16-bit sign-magnitude integers in the Tesla Model S and X. Torque values are produced every 100 milliseconds. Equations for deriving the mapping values can be found in References 2 and 3.<sup>4,5</sup>

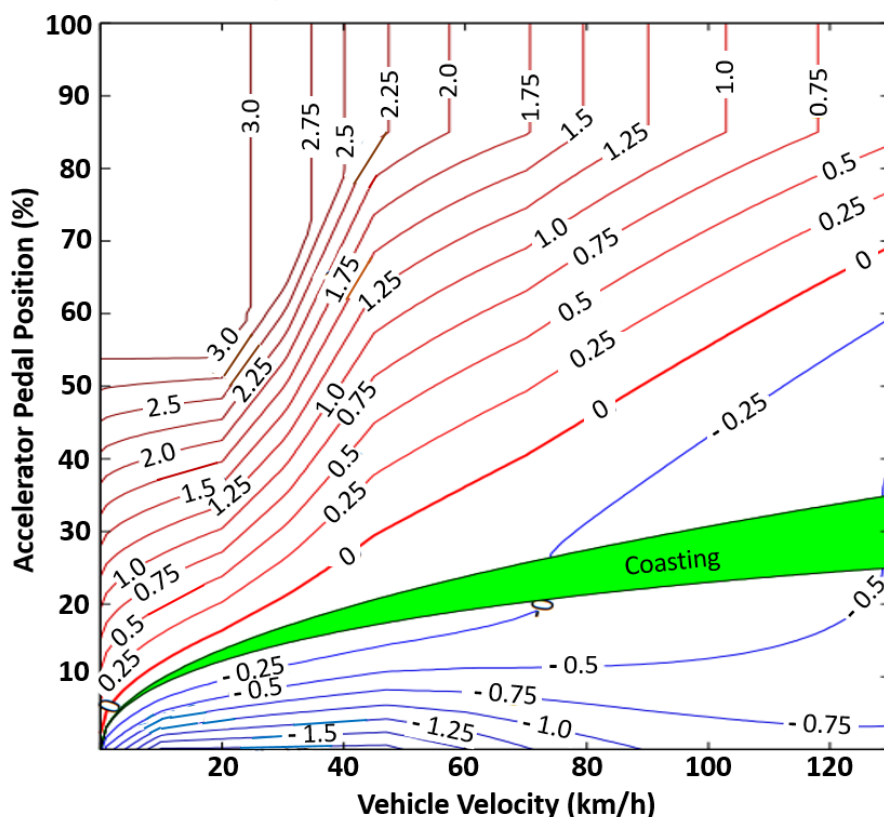

Figure 8. A pedal map translates the accelerator pedal position into a requested torque value. This typical map from a non-Tesla vehicle shows deceleration values in g’s produced by the requested torques when acting on a constant vehicle inertia.<sup>4</sup>

Figure 9 shows the second step in Tesla’s drive motor control system. In this step a drive motor torque map translates the requested torque values from the pedal map into torque and magnetic field flux commands to the drive motor. The map consists of a two-dimensional look-up table

accessed by the pedal map torque and the vehicle velocity. Table outputs for pedal map torques and vehicle velocities lying in between those on the two axes are obtained by two-dimensional interpolation of values that are in the map. Figure 9 shows only the resulting torque commands. Positive motor torque commands in the forward driving quadrant enable driving in the forward direction while drawing power from the battery. They may vary in magnitude from 0 g's to 1.0 g's at 100% of motor torque. The dashed line in Figure 3 shows a typical acceleration profile, which can be any compound curve in the forward driving quadrant. Negative motor torque commands in the forward braking quadrant enable regen braking with associated recharging of the drive battery. They are limited by several factors to only a small part of the available motor torque profile, as discussed below. The remainder of the forward braking quadrant goes unused. The dashed line in Figure 3 shows a typical regen path in the forward braking quadrant.

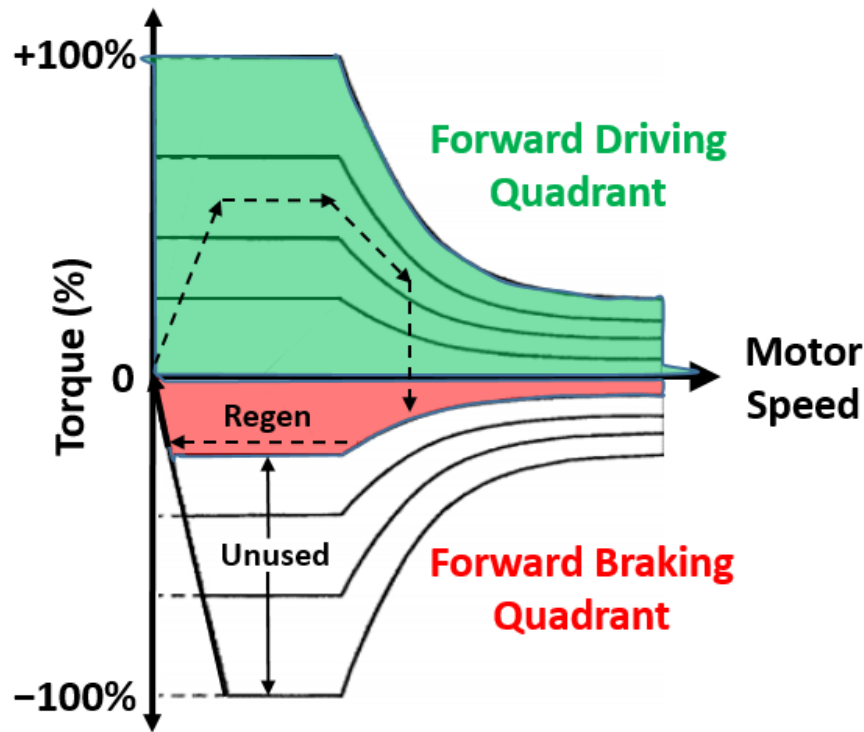

Figure 9. A drive motor torque map translates the requested torque values from the pedal map into torque and magnetic field flux commands to the drive motor.

Figure 10 shows in greater detail the red regen portion of the motor torque map of Figure 9. The maximum braking torque is limited by the maximum deceleration level of -0.2 g's to -0.3 g's by the desire to avoid vehicle instability when suddenly applying regen on roads with degraded friction coefficients. At this maximum negative torque, as the motor speed increases, its back *emf* also increases until it becomes equal to the excitation voltage, at which point the motor speed cannot be increased. To increase the motor speed further, the *emf* is reduced by reducing the motor's field current in proportion to the inverse speed  $\omega$ . Since torque is proportional to motor current, the torque decreases as  $1/\omega$  in this field weakening region. The power is proportional to torque times the vehicle speed  $\omega$ , and remains constant in this field weakening region.

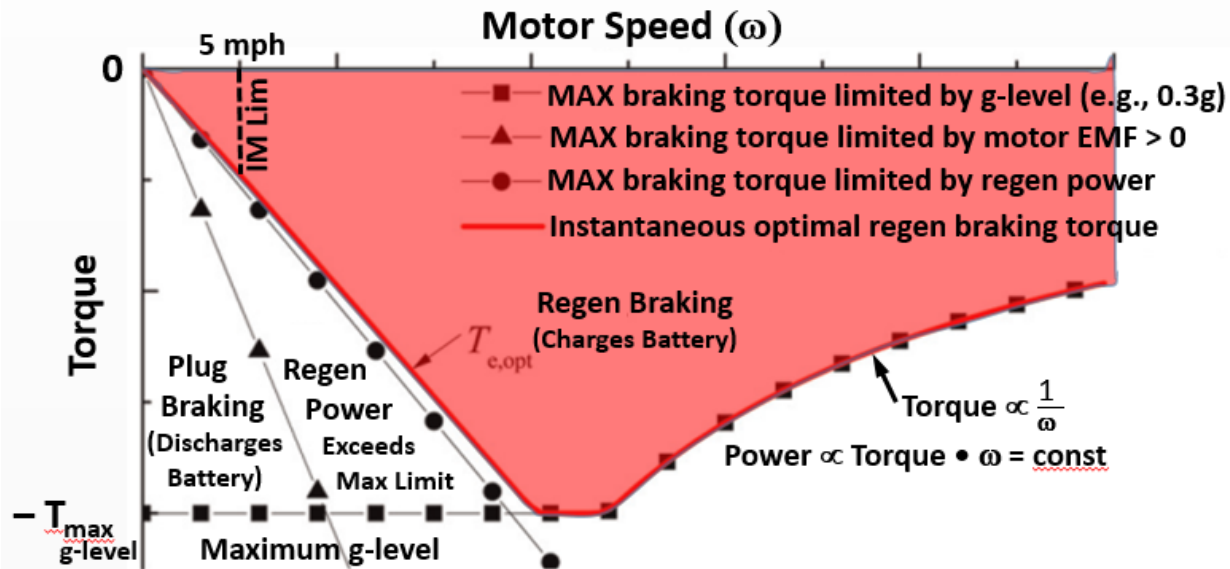

Figure 10. Detailed view of the regen portion of the motor torque map showing the various factors limiting regen<sup>6</sup>

At any given torque below the maximum braking torque, as the motor speed decreases the regen power and braking torque decrease in proportion to the motor speed  $\omega$ . The rate of decrease is limited by the maximum regen power, which must be kept less than some maximum value determined by battery charging circuitry, as shown by the dotted line in Figure 10. If this maximum power is increased by a different design, one eventually becomes limited by the back *emf* voltage which must remain above some minimum value for effective battery charging, as shown by the line with triangles in Figure 10. Below this minimum *emf* voltage, braking torque is possible only by drawing power from the battery, which is known as plug braking in the technical literature. It is important to note that the motor will still operate in all areas of the forward braking quadrant (second quadrant). Operation in the desired regen braking region (red area in Figure 10) is obtained only by limiting the torque request at a given speed.

Within the regen braking region as described by the above limits, it is possible to obtain any desired braking torque and regen power by providing the drive motor with the appropriate torque and field flux commands. Vehicle deceleration follows a path anywhere in this region as the vehicle speed, which is directly proportional to the motor speed, decreases. At vehicle speeds below 5 mph, induction motors cannot generate any effective braking torque or regen power because their rotor fields are limited by induction currents which become too low for practical use. However, motors having rotors with embedded permanent magnets can still create rotor fields large enough to allow operation below 5 mph. Tesla introduced such internal permanent magnet (IPM) motors in their Model 3 vehicles, and plans to use them in all new versions of their Model S and Model X lines.

Figure 11 shows the operating points used in a drive motor torque map while following a typical urban driving cycle. The driving cycle is EPA's standard Urban Dynamometer Driving Schedule (UDDS) driving cycle as shown in Figure 12. The operating points are shown in red, and clearly show the positive acceleration torques and negative braking torques used. The linear variation of braking torque with vehicle speed at low vehicle speeds is readily apparent.

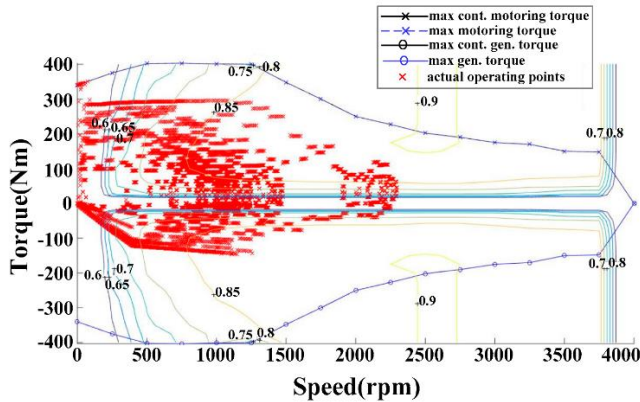

Figure 11. Efficiency contours and operating points in a drive motor torque map while following EPA's UDDS driving cycle.<sup>7</sup>

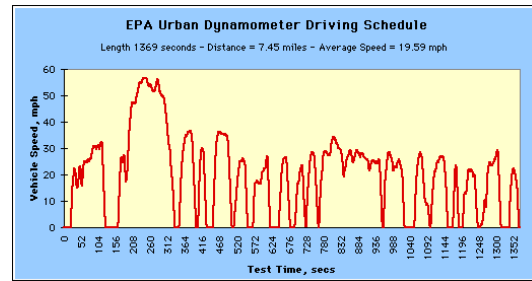

Figure 12. Vehicle speed profile used in EPA's Urban Dynamometer Driving Schedule (UDDS) cycle.<sup>8</sup>

It is well known that many Tesla vehicles have dual drive motors. Figure 13 shows how regen behaves in a Tesla Model 3 with dual drive motors as it slows down from 100 kph to 0 kph. As the vehicle speed decreases, all the regen torque and power are provided by the rear drive motor only, which produces the maximum regen possible. The braking torque corresponds to  $-0.3 g$ 's, the maximum for a Model 3 with software update 2018.42 v9. At low speeds the regen torque and power decrease linearly with speed as expected. Figure 14 shows the same situation as Figure 13 except when there is snow on the road that creates slip between the road and the tires. When slip is present, one finds that some of the rear motor braking torque is transferred to the front motor, with the sum of the two torques remaining constant near the original maximum value. Why is this happening?

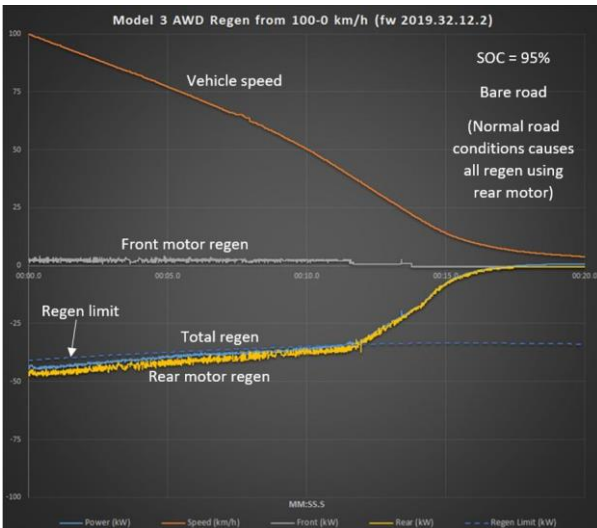

Figure 13. Regenerative behavior of a Tesla Model 3 with dual drive motors as the vehicle speed decreases.<sup>9</sup>

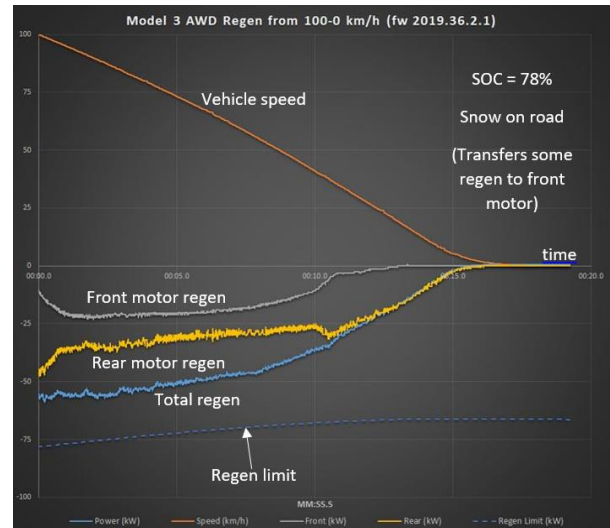

Figure 14. Same situation as Figure 13, but with slip occurring between the road and the tires.<sup>10</sup>

The reason for this behavior is that regen torque is a braking operation. And when braking torque is applied to the rear wheels while slip is occurring as a result of snow, ice, rain, or gravel, the rear wheels can lock up due to lack of traction. Without rear wheel traction, the vehicle can become unstable and go into a hazardous spin about its vertical axis that cannot be controlled. Therefore, government regulations require the vehicle manufacturer to use a certain amount of front wheel braking to prevent this instability from occurring.

The government regulations are based on a brake force distribution curve as shown in Figure 15. As any given vehicle is braked, the deceleration applied causes the vehicle to tilt forward, transferring weight from the rear wheels to the front wheels, changing the horizontal braking forces on the wheels. As weight is removed from the rear wheels, their traction capability is reduced, and they tend to lock up sooner at lower deceleration values as the brakes are being applied. However, transferring too much weight to the front wheels can cause the front wheels to lock up also. It is possible to calculate the horizontal braking forces on the front and rear wheels at which the front and rear wheels will lock up at the same time as a function of the deceleration value, the vehicle's mass, center of mass location, wheel base, and the friction coefficient of the road. If we plot these values as a curve in a plane with the front and rear braking forces as the orthogonal axes, we get the ideal I-curve shown in Figure 15. Above the I-curve the rear wheels will lock first, which is an unsafe condition expressly forbidden by the government regulations. Below the I-curve any operating points are considered safe except for points below an M-curve which defines the minimum rear braking force for the vehicle. The slanted lines show the deceleration values for each point along the I-curve. The  $\beta$ -curve shows the operating points associated with the linear brake proportioning valve used in most ICE vehicles on the road today.

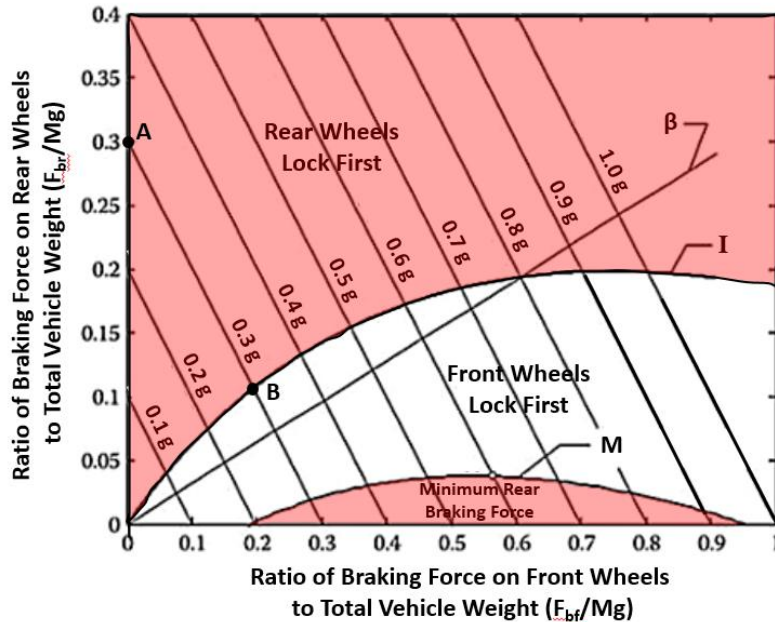

Figure 15. A typical brake force distribution plot used to determine allowable front and rear braking forces as a function of vehicle deceleration<sup>11,12</sup>

Using Figure 15, we can now explain the regen behaviors of the Tesla Model 3 vehicle shown in Figures 13 and 14. The Figure 13 regen behavior is shown as point A in Figure 15, lying on a line having a deceleration value of 0.3 g. At point A all braking is provided by the rear wheels only, which puts it deeply in the unallowable region where the rear wheels will lock up first. This is tolerable only if the rear wheels have 100% traction on the road, or no slip. If any slip is present, then to keep the vehicle stable at the same deceleration value, the rear wheel braking force must be reduced while increasing the front wheel braking force in order to move the operating point to point B on the I-curve (or below) in Figure 15. At point B the front and rear braking forces are roughly equal at 0.2 g and 0.1 g, respectively. This corresponds to the regen behavior of the Tesla Model 3 with slip present as shown in Figure 14. (Figure 15 is not specific to the Tesla Model 3, so quantitative agreement with Figure 14 should not be expected).

We will now explain how this regen force distribution function is done in Tesla’s traction control system. Figure 16 shows the traction controller as part of Tesla’s larger drive motor control system. The vehicle torque command generation function contains the accelerator pedal map shown in Figure 8 that converts the accelerator pedal value into total vehicle torque request. The Optimal Torque Split Function contains two drive motor torque maps that convert the total vehicle torque request into two pairs of motor torque and flux commands, one pair for each of the front and rear motors, as shown in Figure 9. The optimum torque split is one that runs the motors at their most efficient operating points in order to conserve battery power, as shown in Figure 11. This may involve using only one motor at some operating points, however, which provides acceptable vehicle stability only cases where wheel slip is not present. In cases where wheel slip is present, the traction control system redistributes the two torques from the optimum torque split function into two new front and rear torques in order to operate on or below the I-curve in Figure 15. This achieves the desired vehicle stability.

Two more things must be noted about Figure 16. First, it provides front-to-rear torque redistribution for traction control purposes under both acceleration and regen deceleration. However, it does not provide more general differential (i.e., lateral) wheel slip control for other vehicle stabilization purposes such as oversteer or understeer. These more general wheel slip control functions are provided by the vehicle’s braking system. Second, the vehicle torque command generation function has an input from the vehicle stability control system (VSC). This is unexpected, but is not an error, as it appears in four of Tesla’s ten patents on this system. This seems to give the VSC system authority over the vehicle’s motor torque control, in addition to the accelerator pedal. More will be said about this input in the next section on Tesla’s braking system.

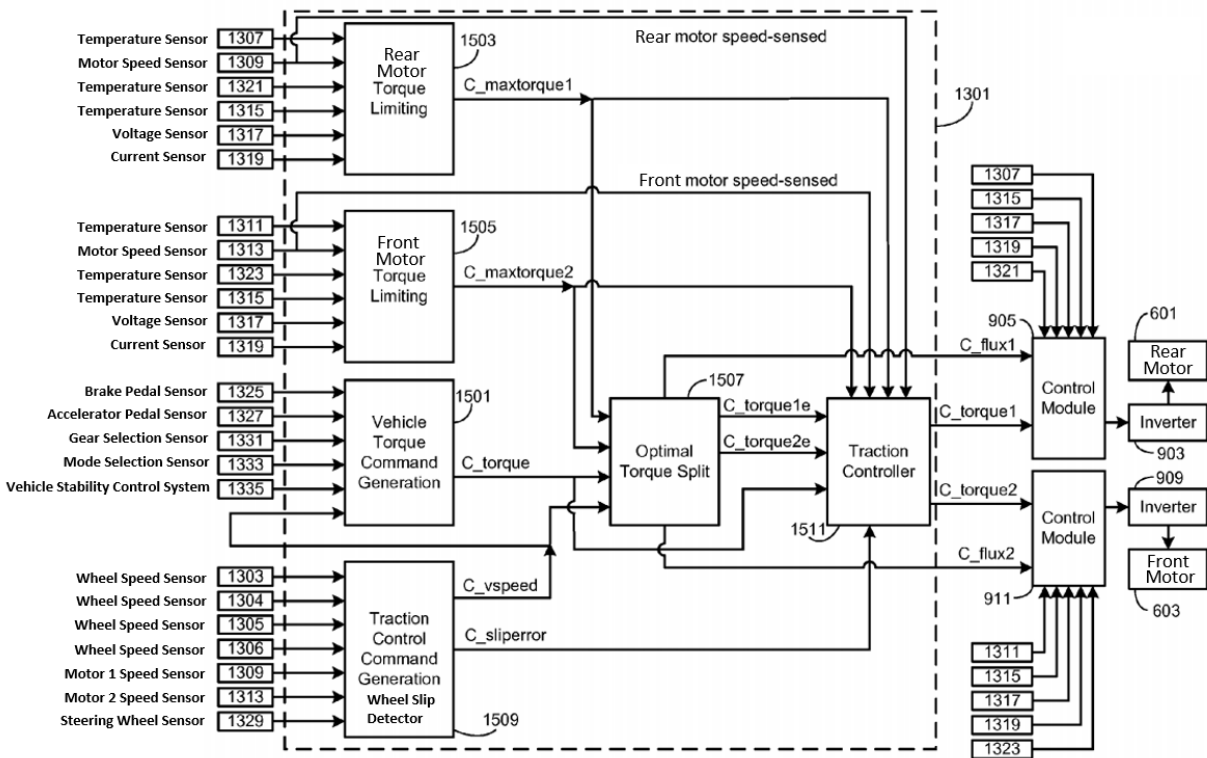

Figure 16. Tesla’s drive motor control system.<sup>13</sup> Computed signal values C\_nnnn are 8-bit sign-magnitude integers in the Model 3 and 16-bit sign-magnitude integers in the Models S and X that are recomputed every 10 ms (100 Hz). Redundant signals are not used.

Figure 17 shows a block diagram of Tesla’s traction controller function.<sup>Note 1</sup> The controller consists of four sections. The first section contains the first stage of traction control which independently minimizes wheel slip using a PID-based feedback control system.

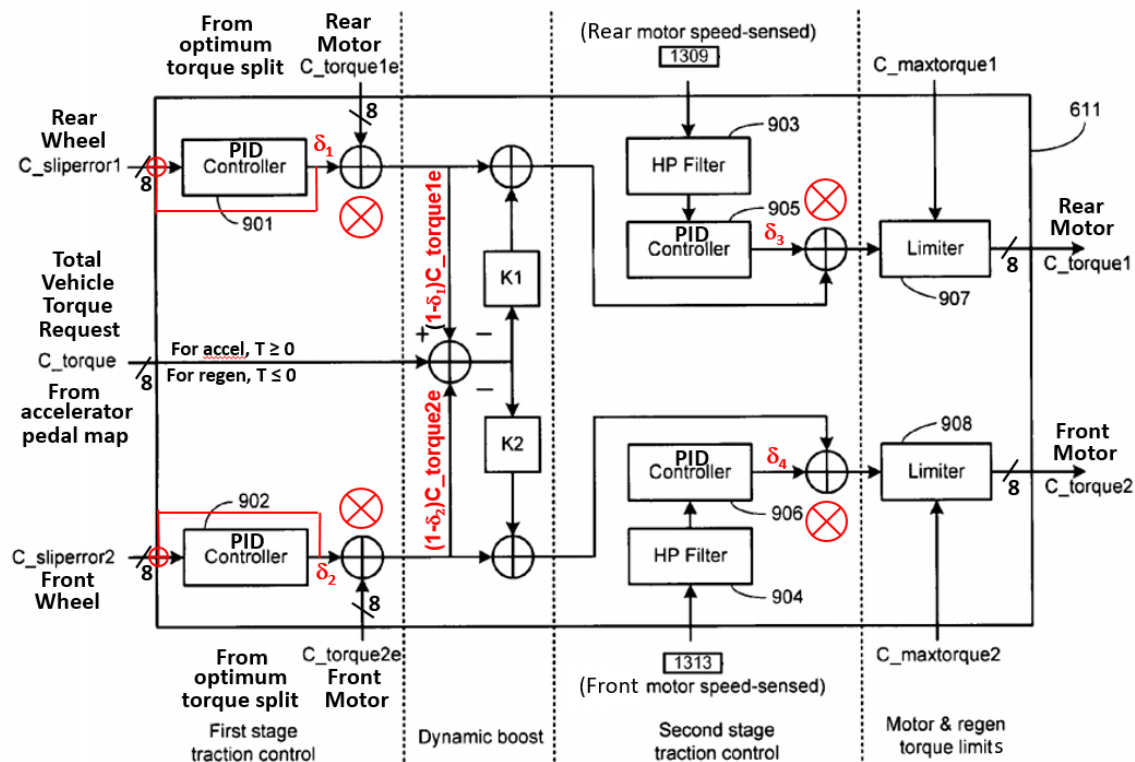

Figure 17. Block diagram of Tesla’s traction controller.<sup>14</sup> Computed signal values C\_nnnn are 8-bit sign-magnitude integers in the Model 3 and 16-bit sign-magnitude integers in the Models S and X that are recomputed every 10 ms (100 Hz). Additions in red are explained in footnote 1.

When wheel slip occurs on either the front or rear wheels, the torque on that axle is reduced and transferred to the other axle that has a lower wheel slip. This is seen from the following equations, which are obtained from Figure 17:

$$C\_torque1 = (1 - \delta_1) C\_torque1e + K1 \cdot (C\_torque - (1 - \delta_1) C\_torque1e - (1 - \delta_2) C\_torque2e)$$

$$C\_torque2 = (1 - \delta_2) C\_torque2e + K2 \cdot (C\_torque - (1 - \delta_1) C\_torque1e - (1 - \delta_2) C\_torque2e).$$

Note 1 This block diagram, which appears in ten of Tesla’s patents, shows summing operations in four places that are clearly incorrect because the two inputs have different units (adding apples and oranges can’t result in more oranges). Instead, these four summing operations should be understood as modulation operations (i.e., multiply operations), in which the torque T is pulse width modulated i.e., multiplied) by a duty cycle  $\delta$  between 0 and 1 that results in a reduced torque of magnitude  $(1 - \delta)$  times T. The duty cycle  $\delta$  is determined by a PID controller that drives the current slip ratio to a target slip ratio that is either zero for a straight drive path or some normal minimum slip ratio for a curved drive path, where the minimum slip ratio can change with vehicle speed and steering angle (wheel speeds normally vary during a turn even with no slip). The slip ratio is given by the difference between the wheel speed and the vehicle speed divided by the larger of the two. The input to the PID controller is the slip error, which is the difference between the current slip ratio and the target slip ratio, which is obtained from a look-up table. The PID controller drives this slip error  $\delta$  to zero, which drives the torque from some reduced value  $(1 - \delta) T$  when wheel slip is present to the full value T commanded when no wheel slip is present.

With no slip on either axle,  $\delta_1 = 0$  and  $\delta_2 = 0$ , and we get:

$$\begin{aligned} C\_torque1 &= C\_torque1e + K1 \cdot (C\_torque - C\_torque1e - C\_torque2e) \\ &\approx C\_torque1e \end{aligned}$$

$$\begin{aligned} C\_torque2 &= C\_torque2e + K2 \cdot (C\_torque - C\_torque1e - C\_torque2e) \\ &\approx C\_torque2e, \end{aligned}$$

As expected, this shows that the output torques  $C\_torque1$  and  $C\_torque2$  are merely the same as the input torques  $C\_torque1e$  and  $C\_torque2e$ , respectively.

If we have maximum slip on axle 1 and no slip on axle 2, then  $\delta_1 = 1$  and  $\delta_2 = 0$ , and we get:

$$\begin{aligned} C\_torque1 &= K1 \cdot (C\_torque - C\_torque2e) \\ &\approx K1 \cdot C\_torque1e \end{aligned}$$

$$\begin{aligned} C\_torque2 &= C\_torque2e + K2 \cdot (C\_torque - C\_torque2e) \\ &\approx C\_torque2e + K2 \cdot C\_torque1e \end{aligned}$$

In this case, the output  $C\_torque2$  with no slip is increased from  $C\_torque2e$  to  $C\_torque2e + K2 \cdot C\_torque1e$ , which transfers torque from axle 1 to axle 2. Meanwhile, the output  $C\_torque1$  with slip is reduced from  $C\_torque1e$  to  $K1 \cdot C\_torque1e$ , which reduces the slip but provides a dynamic boost component  $K1 \cdot C\_torque1e$ .

In the second stage of traction control (third section) motor speed fast disturbances are independently minimized using a high pass filter and a second PID-based feedback controller. Motor speed fast disturbances can be caused, for example, by sudden large reductions of load torque on the motor shaft during an excessive wheel slip event, or by sudden large additions of load torque on the motor shaft from one or two stuck wheels.

Between the first and second stages is a transient torque boost feedforward control circuit, referred to in the figure as dynamic boost, which adds an amount of torque to each axle. The amount of torque added is proportional to the difference between the driver torque request after the first stage of traction control and the combined torque command,  $C\_torque$ . The proportional constants  $K1 < 0$  and  $K2 < 0$  can be tuned to be different values for the two axles. The feedforward torques enhance the vehicle performance, vehicle response to driver request and drivability without compromising traction control and vehicle stability. The feedforward torques are zero when the torque request is fully met, with zero effective wheel slip ratio errors and with the maximum torque limits not in effect. During a wheel slip event that causes a torque reduction on an axle, an effect of the feedforward control is to increase the torque command to the other axle that has a better tire-to-road grip. The feedforward control also adds a torque command to the axle experiencing wheel slip, but due to the relatively smaller gain in the feedforward path, the wheel slip ratio error feedback loop still dominates and will minimize the wheel slip ratio error.

After the second stage of traction control, in the last section, torque limiters independently limit the torque commands issuing from the second stage based on  $C\_maxtorque1$  and  $C\_maxtorque2$ . This stage assures operation in the the regen portion of the motor torque map of Figure 10 when the torque is negative. The output of the torque limiters are torque commands  $C\_torque1$  and  $C\_torque2$ .

This controller only provides traction control in response to longitudinal wheel slip that can be minimized by front-to-rear torque redistribution. It does not provide stability control functions based on lateral wheel slip that are solved by left-to-right torque redistribution, like oversteer and understeer. These additional stability control functions must be supplied by the vehicle's braking system.

Before discussing Tesla's braking system, it must be mentioned that some of Tesla's vehicles, including the Model 3 described in Section 1, have only a single rear drive motor. In this case, regen torque can't be transferred from the rear drive wheels to the front drive wheels because

there is no front drive motor. Yet, the vehicle stability requirements of Figure 15 must still apply. The only solution in this case is that some of the regen torque is transferred from the rear drive axle undergoing slip to the front wheel friction brakes. This may sound to some readers like brake blending, which others have argued that Tesla does not do. More will be said about this in the next section.

#### IV. Tesla Braking System

The service braking system used on all Tesla vehicles consists of three major components:

- 1) a brake booster with its associated electronic control module containing a brake force distribution function,
- 2) a brake modulator unit with its associated electronic control module containing slip control functions for ABS and ESC.
- 3) four wheel assemblies that contain the disc brake actuators and brake pads along with wheel speed sensors.

There is also a completely separate parking brake system with its own controller and brake actuators and pads that will not be discussed here.

The brake booster used in Tesla's brake system is Bosch's iBooster as shown in Figures 18 thru 21. It uses an electric motor to provide brake pedal assist or boost instead of a large circular



Figure 18. Bosch's 1st gen iBooster with tandem master cylinder.<sup>15</sup>

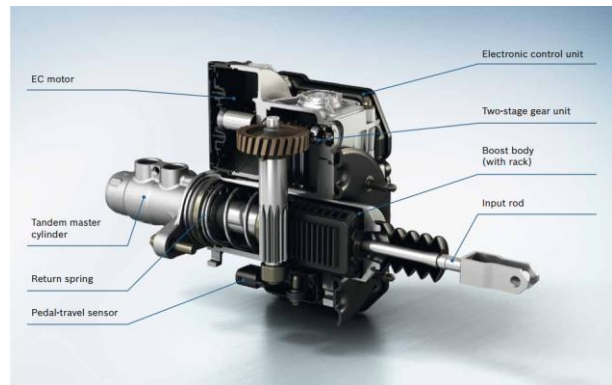

Figure 19. Cross section of the 1<sup>st</sup> gen iBooster showing the electric motor and gear drive.<sup>16</sup>

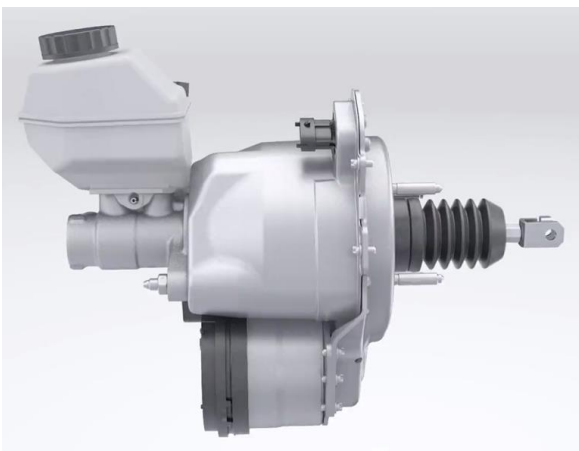

Figure 20. Bosch's 2<sup>nd</sup> gen iBooster used in Tesla vehicles.<sup>17</sup>

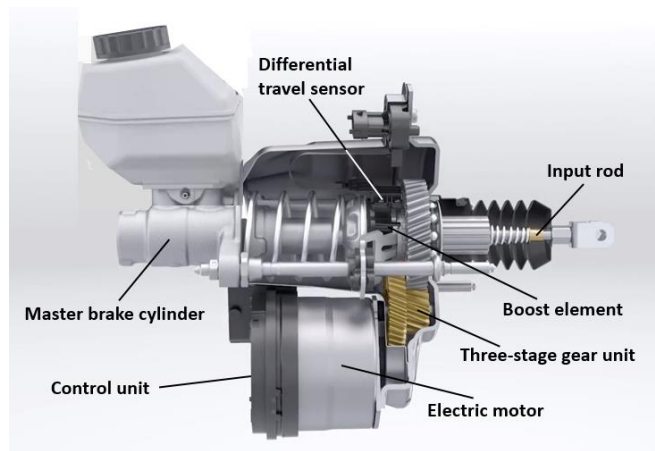

Figure 21. Cross section of Bosch's 2<sup>nd</sup> gen iBooster showing the three-stage gear unit.<sup>18</sup>

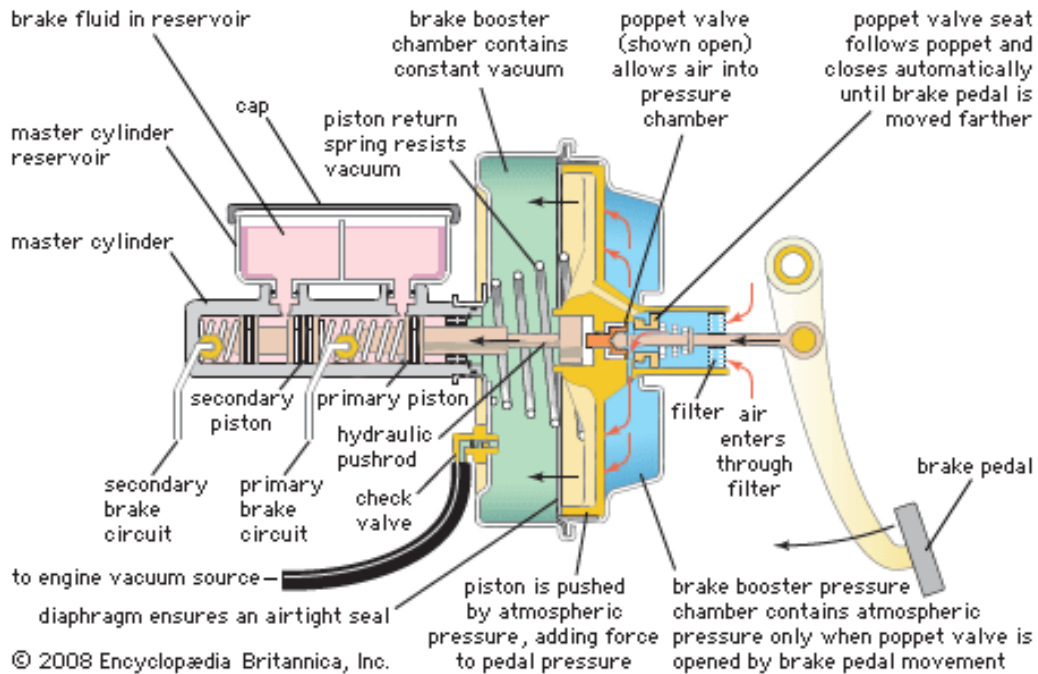

Figure 22. Cross section of a conventional vacuum booster used on most vehicles on the road today

vacuum chamber as used in the conventional vacuum booster shown in Figure 22. Besides the electric motor that provides the power boost, the Bosch iBooster contains a boost motor controller with PID feedback control and high power drive transistors, a tandem master cylinder that supplies brake pressure to the front and rear brake actuators, two brake pedal travel sensors that enable dual redundant sensor outputs, and a programmable electronic control unit. It also uses an external brake lamp/STOP switch to sense brake pedal depression for purposes of brake light activation and control of related vehicle functions. The control unit translates the driver's force on the brake pedal into hydraulic pressure on the brake fluid as well as electronic commands to the solenoid valves in the brake actuator module, enabling them to control the transfer of the brake fluid from the master cylinder to the front and rear brake actuators with an appropriate brake force distribution function. For safety considerations, the iBooster is designed to allow the driver to apply the brakes manually if boost power is lost for any reason. Although the iBooster is used in Tesla vehicles for these purposes, it is not essential for them because the same functions could be provided by a conventional vacuum booster. This shows that the iBooster is desired for other reasons, as discussed Appendix I.

The brake modulator unit used in Tesla's brake system is Bosch's ESP hev II module as shown in Figure 23. It is a special version of Bosch's newest ESP 9.0 ABS modulator that is specifically adapted for use in hybrid electric vehicles. Figure 24 shows that the unit consists of over twelve electrically operated solenoid valves of various types, two hydraulic pressure pumps, an electric motor to operate the pressure pumps, a PID controller with feedback control and high power drive transistors to operate the electric motor, accumulators, pressure sensors, and an overall electronic control module for issuing commands to the pumps and solenoid valves. The control module receives commands from the iBooster via a high speed serial CAN bus. Response time for commands is one millisecond to enable fast braking operations in emergency situations.



Figure 23. Bosch's ESP hev II brake modulator unit.<sup>19</sup>

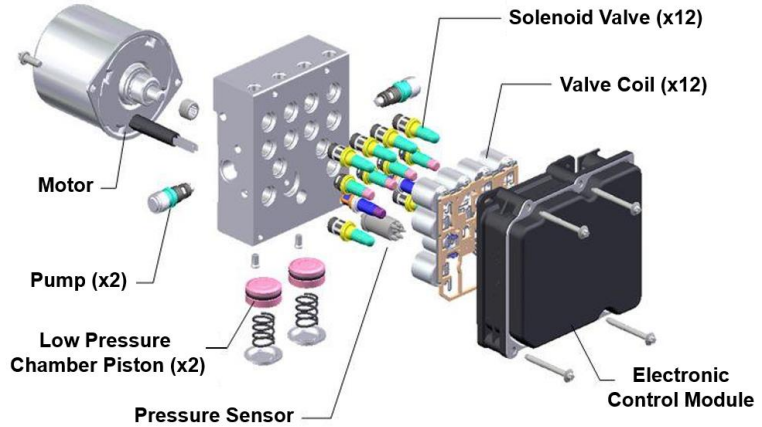

Figure 24. Expanded view of Bosch's ESP hev II unit showing its internal components.<sup>20</sup>

Figure 25 shows how the iBooster and the ESP hev II brake modulator work together to achieve brake operation. The valves are shown in their normal operating positions when power is off, which allows the transfer of pressurized brake fluid from the master cylinder to the wheels to allow normal manual operation of the brakes. Besides mechanical activation of the brakes by the brake pedal, the system also allows electrical activation independently of the brake pedal by closing the isolation valves from the master cylinder and activating the pressure pumps to provide the desired brake pressure to the wheels. This electrical activation can be done on either channel separately while the other channel is operated manually or on both channels at the same time. When electrical activation is used on either channel, the driver can feel the brake pressure provided by the electrically activated pressure pump as it is fed back into the master cylinder via a pressure relief valve, as shown by the right hand channel in Figure 25. In hybrid electric vehicles, it is often desirable to prevent the driver from feeling the electrically activated brake pressure in order to hide changes in the manually operated brake pressure caused by brake blending operations associated with regen. Therefore, Bosch has modified its existing ESP 9.0 modulator for this purpose by returning the brake fluid from one channel back to the fluid reservoir instead of the master cylinder as shown on the left channel in Figure 25. This prevents the driver from feeling the electrically activated brake pressure in this channel. This also requires a special kind of pressure relief valve as shown in yellow in Figure 25. Together, these ESP hev II modifications support brake blending operations in a hybrid electric vehicle. Tesla vehicles use the ESP hev II unit with the left-hand channel on the rear wheels and the right-hand channel on the front wheels<sup>Note 2</sup>. This allows the left-hand channel to electronically blend (i.e., substitute) friction brake pressure with regen brake pressure in any amount up to 0.3 g, as limited by the maximum pressure provided by the electric pump in the modulator unit.

---

Note 2. Most non-electric vehicles use a so-called diagonal or X-split, configuration in which one channel activates the left front brake and the right rear brake while the other channel activates the right front brake and the left rear brake. This is done to maintain at least one front brake for additional safety in case one channel is lost. Hybrid electric vehicles, on the other hand, prefer the so-called parallel or front-rear configuration for ease of implementing blending operations between friction brakes and regen braking.

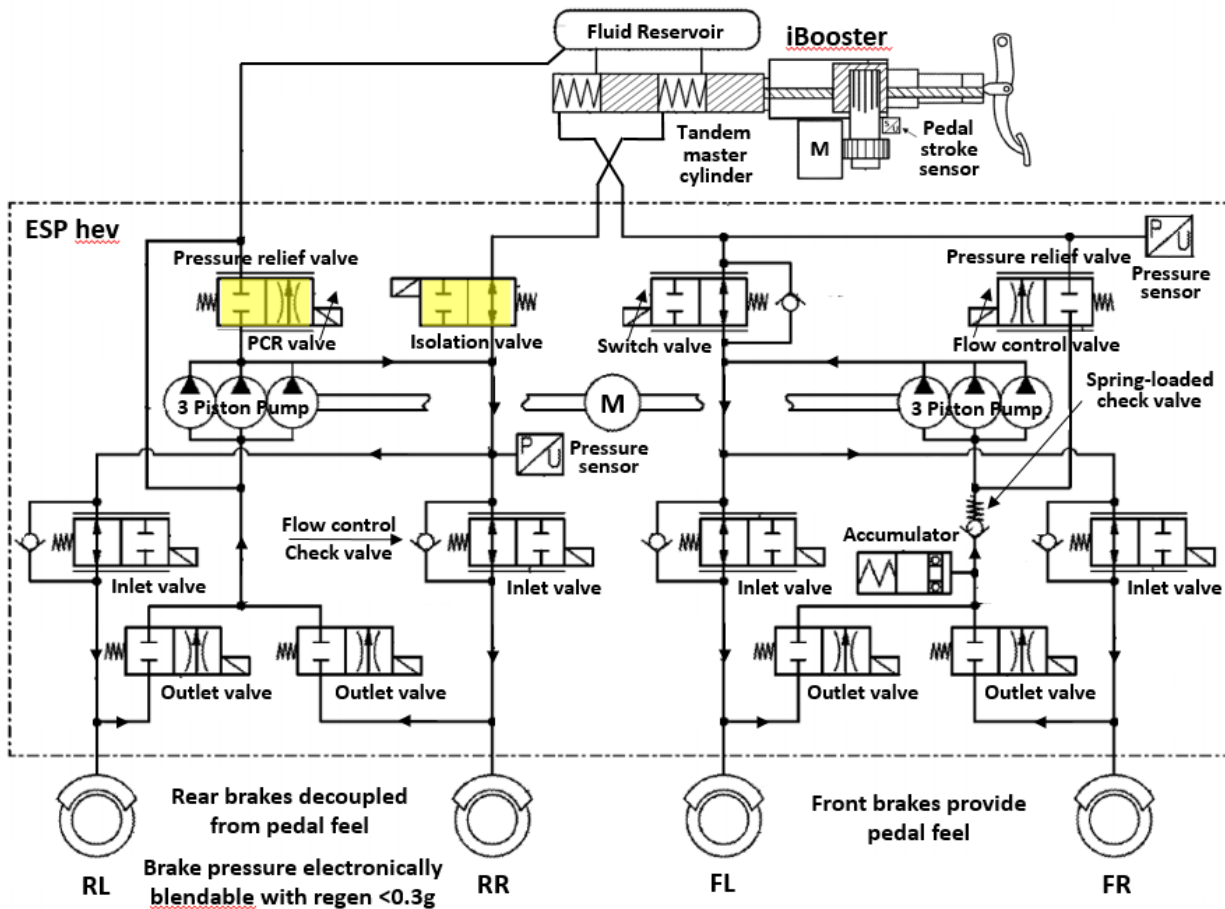

Figure 25. Hydraulic valve system diagram showing how the valves in the ESP hev II module work together with the iBooster module. Valves are shown in their normal operating positions when power is off, which allows the transfer of pressurized brake fluid from the master cylinder to the wheels.<sup>21</sup>

One operation the modulator in Figure 25 cannot support is the transfer of regen braking force from the rear motor into friction braking force on the front wheels while the driver is applying friction braking force to the front wheels. This is essential in a vehicle having only one rear drive motor such as the Tesla Model 3. Therefore, Bosch has added another modification to its ESP 9.0 modulator in the form of an electronically operated plunger as shown in Figure 26. The plunger uses an electric motor to push a piston that forces brake fluid out of a storage chamber, thereby increasing the brake pressure just like the master cylinder increases brake pressure in response to a piston pushed by the driver. This modification is not needed on dual drive motor vehicles, so it is unknown whether all Tesla vehicles use this modification or whether vehicles with only rear drive motors do, because it does increase the cost of the modulator.

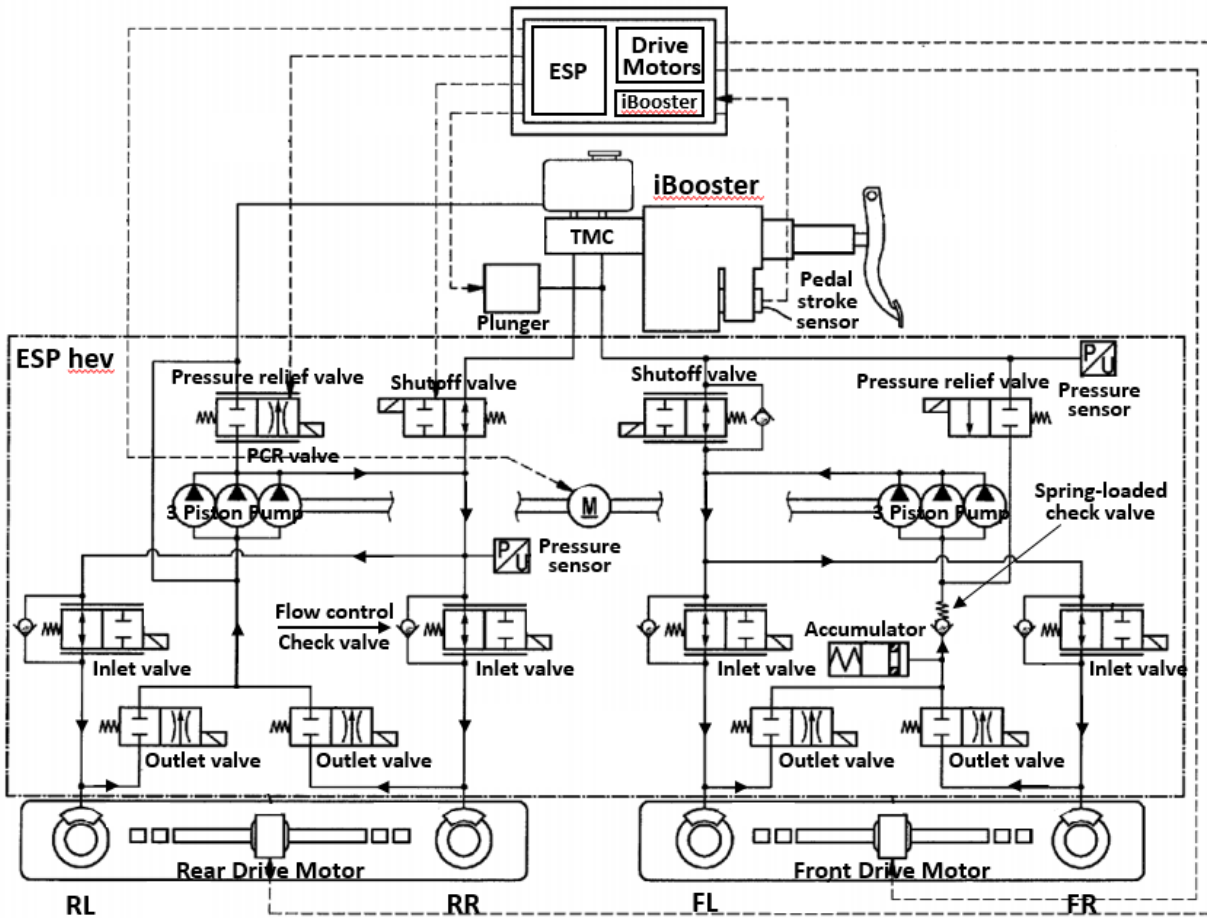

Figure 26. Variation of Bosch's ESP 9.0 modulator shown in Figure 25 that adds a plunger for electrical activation of the front brakes while the front brakes are being activated manually.<sup>22</sup>

By using one of the ESP modulator units shown in Figures 25 or 26 it is possible to do brake force distribution of the friction brakes when the brake pedal is applied that meets the government requirements shown in Figure 27. In this case, the iBooster provides the instructions to the ESP modulator on how to distribute the total vehicle braking force to the front and rear wheels, and the ESP modulator carries out these instructions by suitable control of the modulator solenoid valves and modulator pressure pumps. Instructions are provided via a high speed CAN bus. Instructions can be devised to provide any given deceleration path in the unshaded (white) portion of Figure 27. The dashed blue line is one example of such a path. In a vehicle with rear wheel drive, this path is likely to follow the ideal I-curve shown in Figure 27. The distance from the origin to any point along the path gives the deceleration value  $z$  (also known as the braking strength or braking severity), which is proportional to the TMC pressure or the total braking force. This brake force distribution operation is distinguished from the brake force distribution of the regen braking torque in Figure 15 by applying to the total braking force when the brake pedal is pressed (i.e., friction brakes as well as regen braking), instead of applying to regen braking only when no brake pedal is pressed as shown in Figure 15.

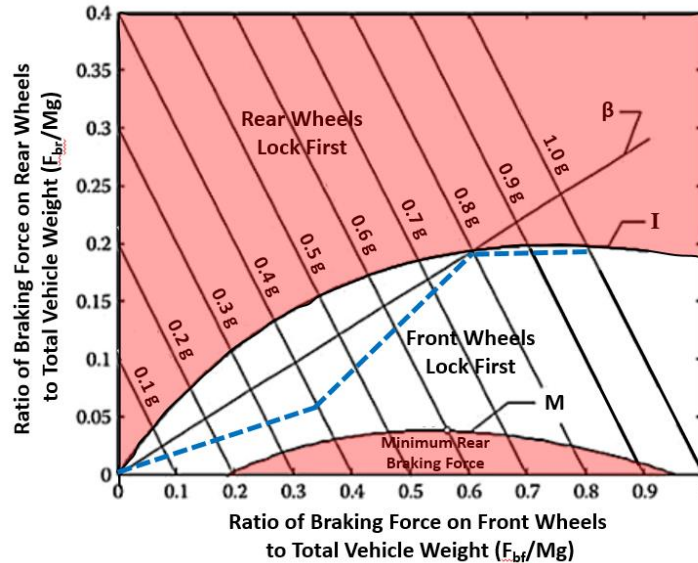

Figure 27. Brake distribution function for the total brake force (friction plus regen).<sup>23</sup>  
 The dashed blue line shows an arbitrary distribution function possible using the iBooster.

Friction brake application, either manual or electrical, with the proper brake force distribution between the front and rear wheels, is only half of the functions performed by the ESP hev modulator unit. The other half of the functions are slip control functions that provide electronic vehicle stabilization. These slip control functions include the following:

1. **Anti-Lock Braking System (ABS).** The ABS controller constantly monitors and compares signals received from four speed sensors located at each wheel. When the brake is applied and a wheel is about to lock, the ABS modulator reduces the brake pressure at the unstable wheel enough to prevent wheel locking. As soon as the wheel becomes stable, the ABS controller increases brake pressure, thereby maintaining optimal braking force at all times. The ABS control system performs these adjustments several hundred times per second on each wheel independently. This enables the driver to achieve the highest brake force physically possible, while maintaining vehicle stability and steering over any road surface.
2. **Dynamic Traction Control (DTC).** DTC prevents excessive motor torque from reaching the driven wheels. By monitoring wheel speeds, the TCS controller in the brake system can modulate and reduce motor torque on only one driven wheel at a time by braking the slipping wheel to keep it from spinning. The operation is similar to ABS, but takes place during acceleration instead of deceleration as with ABS. This function provides improved traction control when only one side of the car is driving over a low traction surface, such as patchy ice, where only one driven wheel has low grip. Therefore, DTC augments the operation of the traction controller in Tesla's drive motor control system, which removes torque from both wheels on one axle at the same time, by imitating the function of a conventional differential lock. This function is especially useful when accelerating or driving up a hill on a loose surface or in deep snow.
3. **Dynamic Brake Control (DBC)** DBC assists the driver in panic or emergency braking situations by automatically boosting the brake pressure. In emergency braking situations, drivers often fail to apply sufficient pedal force to achieve the maximum vehicle deceleration. ABS regulation is then not activated. The DBC control unit monitors inputs from the brake light switch and the brake pressure sensor. The trigger for activation of DBC is how rapidly the brake pressure is increasing with an application of the brake pedal. If the trigger condition indicating an emergency braking event is satisfied, DBC uses the ABS pressure

pump to increase brake pressure when the driver's pedal force is insufficient. Hydraulic brake pressure is artificially increased much faster than pressure from the driver, and is maintained at the optimal ABS operating pressure. This pressure increase is done in the following situations: a) when the brake pedal is rapidly depressed with insufficient pedal force, or b) when the brake pedal is depressed slowly and the demand for deceleration is subsequently high, after one wheel reaches the ABS control threshold. This function is useful when the traffic slows, making light braking necessary at first, but then something happens that demands as short a stopping distance as possible. It is active at any speed above 3 mph. This function is sometimes called Dynamic Brake System (DBS) or Brake Assist System (BAS).

4. **Automatic Emergency Brake (AEB).** AEB decelerates the vehicle without the driver having to use the brake pedal when the probability for forward collision is predicted as high. The purpose of AEB is to eliminate or mitigate collisions where subject vehicle collides with a lead vehicle. AEB uses the friction brake system as actuator, up to full brake which would be typically  $10 \text{ m/s}^2$ . An AEB system must be designed to not trigger too early, because the driver could be disturbed by it, thereby actually causing accidents. Therefore, in many situations, AEB will mitigate collisions rather than avoid them
5. **Corner Brake Control (CBC).** CBC can activate if the vehicle is cornering while ABS regulation is not taking place. When a transverse acceleration in excess of  $0.6 \text{ g}$  is detected while the brakes are being applied, the CBC prevents a buildup in brake pressure to the inside rear wheel or the outside front wheel. The difference in braking force between the two wheels on the same axle creates a yaw force that opposes the transverse acceleration and allows the vehicle to handle neutrally. The CBC controller accomplishes this by closing the inlet valve, thus not allowing brake pressure to increase at the brake caliper of the desired wheel. This attempts to prevent the vehicle from entering into an unstable situation that can lead to understeer or oversteer. This function only works while the brakes are being applied.
6. **Electronic Stability Control (ESC).** ESC maintains control of the vehicle during cornering. It uses yaw rate and acceleration sensors in addition to wheel speed sensors. ESC calculates the intended path of the vehicle using inputs from a steering angle sensor and compares it to the measured rate of turn of the vehicle from the yaw rate sensor. This allows it to monitor for understeer or oversteer events during cornering. In the case of understeering, the rear inside wheel is braked, resulting in a positive yaw torque that helps the vehicle turn into the corner. During oversteering, the front outside wheel is braked resulting in a negative yaw torque that steers the vehicle out of the corner and helps the rear axle regain traction. ESC also controls and limits engine power to the extent necessary to support lateral tire grip during cornering. This function works when the brakes are not being applied or when the lateral acceleration is less than  $0.6 \text{ g}$ .
7. **Engine Drag Torque Control (EDC).** EDC prevents deceleration torque (i.e., drag torque) from the engine from locking the rear drive wheels, which can generate wheel slip that can cause the vehicle to spin about its vertical axis when decelerating on roads having low friction. The situation is similar to deceleration caused by excessive brake application on a low friction surface, which would normally cause activation of the ABS system that shifts the operating point on the brake distribution curve to one closer to the ideal curve. However, with engine drag causing the deceleration, reducing the deceleration by lowering the braking force using ABS is ineffective because the braking torque is not caused by the friction brakes. Instead, it is caused by the negative drag torque of the internal combustion (ICE) engine, which may be further increased by shifting into a lower gear. The only way of reducing this negative engine drag torque is to increase the engine torque by sending a throttle request to the engine for a higher positive torque when slip is detected that can cause the rear wheels to rotate slower than the front wheels with no brakes being applied. In electric vehicles without an ICE engine, this negative drag torque is produced by the regen

torque of the electric drive motor, which causes a deceleration of about 0.2 to 0.3 g's. If this regen deceleration is applied suddenly on a slippery road, it can cause an unstable situation that requires this function. In this case, the EDC controller sends a torque request to the drive motor to provide a positive torque that will offset, or reduce, this negative regen torque for a short period of time. Since the EDC controller does not know the magnitude of this torque, it can only keep incrementing the torque request in the positive direction until it senses that the slip on the drive axle is zero. This function is provided by the ABS unit in all ICE vehicles and electric vehicles. It is often referred to as MSR, the German acronym for Motor Schleppmoment Regelung (MSR), which is the German translation of Engine Drag Torque Control.

The last drag control function may strike the reader as particularly interesting because it gives the ESP hev II module authority over the drive motor torque. This explains the input to the drive motor torque controller from the Vehicle Stability Control system shown in Figure 16. But this authority should not be enough to cause sudden acceleration because it is limited to increasing the motor torque by only 0.2 to 0.3 g's to offset a negative regen torque to make it equal to zero. Nevertheless, this authority over drive motor torque necessitated a further look at patents to determine how this function operates. This study found several patents that added important details to the explanation of this function. US patent 6535809 by Delphi explained that the brake switch is checked to determine whether the cause of the negative torque is the engine regen torque and not the friction brakes.<sup>24</sup> German patent DE10238224B4 by Bosch revealed that after the wheel slip has been neutralized, the MSR control is continued for a predetermined overrun time, and this overrun time is longer when negotiating a curve than when driving straight ahead, being preferably between one and three seconds.<sup>25</sup> Finally, many patents were found that explained that MSR is more sensitive while cornering than while driving straight ahead.<sup>26,27,28</sup> We will have more to say about this function in Section V.

All of these slip control functions are included in the ESP hev II modulator as software built into the modulator control unit by the brake system subcontractor, who in this case is Bosch. This software is proprietary to the modulator subcontractor and not accessible for modification by the vehicle manufacturer. The software executes under the local control of the ESP hev II module control unit acting as a master on the CAN bus, and the functions are always on. This is contrary to the brake force distribution function, which operates as a slave to the iBooster controller and is active only during manual braking. Although some vehicle manufacturers give the driver the ability to turn off some of these stability control functions, Tesla does not. This makes it impossible for most Tesla drivers to “do doughnuts” or to do tighter turns with induced slipping.<sup>Note 3</sup>

We will now look further into the operation of Tesla's braking system and how its ESP hev II module interacts with the regen system by examining the requirements that government regulations impose on them. Further information on the stability control functions is obtained from patents and technical papers.

## **V. Further Information on Tesla's Braking System and Its Interaction with Regen**

As Tesla vehicles are now being sold internationally, they are subject to government regulations.<sup>Note 4</sup> These regulations specify how the braking system must operate and how its

---

Note 3. Some Tesla drivers have found a way to turn off these functions by activating a secret dyno mode, and Tesla has provided a new Track Mode on Model 3's to do this. See <https://www.teslaincanada.ca/model-3/tesla-has-a-secret-dyno-mode-that-disables-traction-and-stability-control-and-more/> and [https://www.tesla.com/es\\_ES/blog/how-track-mode-works?redirect=no](https://www.tesla.com/es_ES/blog/how-track-mode-works?redirect=no).

Note 4. Tesla's original Roadster did not follow these regulations because it was granted an exception as a result of being an experimental vehicle. But all subsequent Tesla models must follow these regulations.

ABS modulator functions must interact with the regen system. These regulations are provided in the following government documents:

1. United Nations Economic Commission for Europe (UN/ECE) Regulation No. 13-H (2017) with Annexes 1 to 9, “Technical Requirements, Test Methods, and Limit Values for the Braking Systems of Passenger Cars and Light Commercial Vehicles”.
2. United Nations Economic Commission for Europe of the (UN/ECE) Regulation No 140 “Uniform provisions concerning the approval of passenger cars with regard to Electronic Stability Control (ESC) Systems”, 2018/1592
3. USA regulation 49 CFR § 571.126 Federal Standard No. 126; “Electronic stability control systems for light vehicles”.

These regulations are discussed in greater detail in the following government-sponsored reports, which also serve as secondary source material for the requirements:

4. “ID4EV -- Intelligent Dynamics for Electric Vehicles”, a study on the requirements and specifications for electric vehicles derived from user needs and SOTA analysis performed under a European research project co-funded by the Economic Commission for Europe (ECE) under the 7th Framework programme.
5. “Investigation Into Regenerative Braking Systems” by B. J. Robinson, C. Visvikis, T. Gibson, and I. Knight of the Transport Research Laboratory, published project report No. PPR582 for the Department for Transport, Transport Technology and Standards, United Kingdom, 2011.
6. “Functional Safety Assessment of a Generic, Conventional, Hydraulic Braking System with Antilock Brakes, Traction Control, and Electronic Stability Control”, by C. Becker, D. Arthur, and J. Brewer of the Volpe National Transportation Center, DOT report No. DOT HS 812 574, Volpe report No. DOT-VNTSC-NHTSA-16-08, 2018.

These regulations and their associated documents provide the following requirements:

1. "Electric regenerative braking system of category A" means an electric regenerative braking system which is not part of the service braking system; (2.17.2).<sup>29</sup> (Tesla’s regen braking system is Category A).
2. The ESC need not operate below 20 km/h, when in reverse, or when the driver has disabled it.<sup>30</sup>
3. The ESC shall do a start-up self-test within 2 minutes after vehicle starting.<sup>31</sup> (6.2.3)
4. A defective brake light switch (aka STOP lamp switch) can trigger the ESC OFF indicator. A blown brake light bulb can also trigger the ESC OFF indicator.<sup>32</sup>
5. Electric regenerative braking systems as defined in paragraph 2.1.7 of this Regulation, which produce a retarding force upon release of the accelerator control, shall generate the signal mentioned above (ie, brake light signal or STOP light signal) according to the following provisions:

<i>Vehicle decelerations</i>	<i>Signal generation</i>
$\leq 0.7 \text{ m/s}^2$ ( $\leq 0.07 \text{ g's}$ )	The signal shall not be generated
$> 0.7 \text{ m/s}^2$ and $\leq 1.3 \text{ m/s}^2$ ( $0.07 \leq x \leq 0.13 \text{ g's}$ )	The signal may be generated
$> 1.3 \text{ m/s}^2$ ( $> 0.13 \text{ g's}$ )	The signal shall be generated

In all cases, the signal shall be deactivated at the latest when the deceleration has fallen below  $0.7 \text{ m/s}^2$ .<sup>33</sup> (g-equivalents in parentheses added by author). [The maximum regen of

most Tesla models is 0.2 g's, which was increased to 0.3 g's with software update 2018.42 v9].

6. ESC must remain capable of activation even if the antilock brake system or traction control system is also activated.<sup>34</sup>
7. The integration of the regenerative brake system controller into the anti-lock braking system is regulated in paragraph 2.5.18.4. In case an anti-lock braking system is installed, its ECU must incorporate the control of the regenerative brake system. Deactivation of the recuperation by an automated system is explicitly permitted. Therefore an electronic stability control system can deactivate the regenerative braking if required. In the case of the regenerative braking system being linked to the anti-lock brake system, it is subject to the test procedures defined in annex 6 – test requirements for vehicles fitted with anti-lock systems.<sup>35</sup>
8. 12 V DC power supply network. In case ABS, ESC or such like systems apply corrective actions (e.g. in cases of excessive wheel slip, under steer or over steer), the recuperative brake system is deactivated and only friction brakes are used. State of the art brake system controllers do not adapt recuperative brake torque to the driving conditions.<sup>36</sup>
9. If ABS becomes active the regenerative torque shall be controlled or switched off until the end of the brake (BLS = off).<sup>37</sup>
10. ECE R 13-H (additional sections for regenerative braking system to be fulfilled):  
The regenerative brake shall consider the load of the vehicle (chassis level) and the level of adherence. Furthermore it has to be controlled by the ABS controller to avoid excessive wheel slip and to guarantee the stability and the steer ability of the vehicle.<sup>38</sup>
11. ABS activates when the wheels begin to lock. This occurs most easily on surfaces with a low coefficient of friction such as ice. However, when ABS activates, regenerative braking is usually switched off to protect the normal ABS function (Zhang et al., 2010). In these circumstances, the friction brakes would need to compensate for the loss of regenerative braking in order to maintain the same level of deceleration. The strategy for integrating regenerative braking with ABS, and in particular, the timing of the transfer to friction braking, might affect the braking performance of the vehicle and the pedal feel.  
Where vehicles with regenerative braking are fitted with ABS, it is a requirement that the ABS controls the regenerative braking as well as the friction braking in order to enable the system to reduce the wheel torque in the event of lock. However, there is no requirement as to how this should be controlled, so in theory it could be modulated in the same way as the service brake system or simply disconnected. If suddenly disconnected, there is again a general requirement that the friction brake should compensate for the change in deceleration that would otherwise result from disconnection, which may affect pedal feel. The Vehicle Certification Agency (VCA), the UK Government agency responsible for granting type approval to vehicles, interpret this requirement to mean that compensation must be provided whenever the regen component is disconnected. But an alternative interpretation is conceivable; namely, that this compensation (friction brake achieving 75% of its final value within 1 second) is only required where the regenerative braking system alone is providing braking torque prior to the disconnection. The wording of the Regulation is considered a little ambiguous in this regard.<sup>39</sup>
12. ABS. An OEM stakeholder (i.e., manufacturer) suggested that there was unlikely to be any problems with a regenerative system's interaction with the ABS system, because the control algorithms simply switch the regen off as imminent wheel lock is detected by the wheel speed/slip sensors, and the conventional braking system, controlled by the ABS, takes over.<sup>40</sup>
13. ESC. Few studies have been reported on the interaction between regenerative braking and ESC and the effects on vehicle stability. Hancock and Assidian (2005) investigated the impact of regenerative braking on vehicle stability during cornering. A full vehicle model of

a hybrid sports utility vehicle was used for the study (in a computer simulation). They found that applying regenerative braking to the rear axle can reduce stability, depending on (drive) motor size and road surface friction coefficient. With a moderately sized motor on a high  $\mu$  surface, the reduction in stability was controlled by the ESC system without a large increase in ESC brake pressures. However, on a low  $\mu$  surface the reduction in stability was much more severe and could not be compensated for by the ESC. Two solutions were proposed to prevent regenerative braking from causing the wheels to slip; firstly, switching to friction braking once the longitudinal slip of either rear wheel exceeds a specified threshold and, secondly, locking the centre coupling. Both solutions were effective from a stability perspective, but locking the centre coupling had the added advantage of maximizing energy recovery. However, the authors recommended further work to assess the potential effects on ABS/ESC performance.

14. ESC with ABS. Hard braking on a low friction surface will activate the ABS. In the critical test of (hard) braking while cornering, the ESC becomes active. Both occasions will switch off the regenerative brake system (RBS) and none of the brake energy is recuperated. During these events it becomes more important to retain steerability and vehicle stability than recover energy.
15. ESC. Braking-in-a-turn tests would be suitable for investigating the stability effects of low levels of longitudinal deceleration in combination with high lateral acceleration when the brake ratio is strongly biased to one axle as a result of regenerative braking.
16. ABS must control regenerative braking. If the ABS wheel speed signal sees excessive slip, it will trigger suspension of the regenerative braking until the next brake event or lift-off event. For vehicle systems that use non-zero regenerative braking torque when an ABS event occurs, vehicle instability is observed.
17. It is unclear from the existing literature whether current regenerative braking systems, in general, remain switched off when ABS has been activated until the next brake application even if the ABS deactivates during the stop, or if they are simply switched off only when the ABS is activated, and back on again whenever it isn't. The tests conducted for this study (the low-high transition tests) suggest that the test vehicle's regenerative braking system is reactivated once the ABS is deactivated. Some designers specify that the regenerative braking cannot be used again until the next brake application (e.g., Zhang et al., 2008). However, Zhang et al., (2010) proposed a system in which regenerative braking is reactivated when ABS control is ended.
18. Continental markets their regenerative brake system with the statement "The use of a conventional ESC unit enables the regenerative brake system to perform all known braking interventions and stability functions." This essentially brake-by-wire system also has a direct hydraulic push-through in case of brake-by-wire failure. The pressure applied by the driver to the brake pedal is measured and converted into a braking torque demand. The ESC unit is enhanced to communicate with the vehicle's electric drive motor system (motor + battery + battery management). The electric motor system reports to the ESC unit how much regenerative braking torque is available (depending on the state of the charge and temperature). The ESC unit sends back a braking torque demand to the electric drive motor system that does not exceed the available regenerative braking torque and then ensures that the rest of the demand is met by the hydraulic system. There is, therefore, complete flexibility in control to mix braking from the electrical and friction systems, so it is possible to limit the braking to the capabilities of the battery but, at the same time, to maximize energy recapture.
19. According to Economic Commission for Europe (ECE) regulation 13-H, installation of an anti-lock braking system (ABS) in a vehicle is required and must have the supreme priority to take control of vehicle braking in any situation. Similar rules have been promulgated by the United States National Highway Traffic Safety Administration.

20. ABS. The National Highway Traffic Safety Administration (NHTSA) received over 1200 complaints from Toyota Prius owners alleging a momentary reduction in braking performance on uneven road surfaces (NHTSA, 2010). Toyota received nearly 200 further complaints directly. The company performed brake tests in an effort to reproduce this phenomena and found that the braking force reduced after ABS activated. (Toyota, 2010). Further investigations revealed that many drivers had experienced the phenomenon, particularly in winter, where drivers may maintain a fixed pedal stroke. Under these conditions, Toyota found that “vehicle stopping distance may increase, relative to the driver’s expectations for a given pedal force.” The condition was a result of the ABS software, which was permitting a change in braking force. Although the ABS was operating as it was designed to, Toyota conducted a voluntary safety recall to re-program the ABS control unit in the Prius (and the Lexus HS250H). It appears that, in this particular system, the transition from regenerative braking to service braking (i.e., hydraulic braking) was being perceived by the drivers as a change in braking force. Under certain circumstances, the driver would need to press harder on the brake pedal to maintain the same deceleration.
21. Electronic Braking Function requirements:
1. Proportion brake force between front and rear wheels to maximize braking effectiveness.
  2. Proportion brake force between left and right wheels to maximize braking effectiveness.
  3. Control brake fluid pressure to prevent vehicle wheels from locking-up under braking during ABS events.
  4. Provide selective wheel braking during Traction Control System (TCS) events.
  5. Control brake fluid pressure to each wheel to provide vehicle control during Electronic Stability Control (ESC) events, including during extreme dynamic maneuvers and in adverse roadway conditions.
  6. Provide brake force to support other advanced braking features (e.g., hill holder).
  7. Implement braking requests to support other vehicle systems.
  8. Measure and provide the vehicle speed using available sensors and models.
  9. Coordinate yaw rate stabilization with the steering system and other vehicle systems.
  10. Communicate with internal subsystems and external vehicle systems.
  11. Request an increase in torque from the Drive Motor Controller/Electronic Throttle Controller to prevent wheel lock during sudden deceleration.
  12. Request a reduction in propulsion/throttle from the ACS/ETC when needed to support a Traction Control System (TCS) or Electronic Stability Control (ESC) event.

Note that requirements 21.11 and 21.12 specify that the braking system can request either an increase or decrease in torque from the drive motor in response to either a sudden deceleration or a traction control/electronic stability control event, respectively

In summary, these requirements show that regen not under the control of the friction braking system is incompatible with the slip control functions of the brake modulator module. This incompatibility is true not only for Class B vehicles that use the brake pedal for activating regen, and must therefore blend the regen torque with the friction braking torque, but also for Class A vehicles like Tesla vehicles that use the accelerator pedal for one pedal driving. This incompatibility arises because the slip control algorithms in the braking modulator need to know all the braking forces acting on the vehicle at the time the algorithms are active, and lose their effectiveness when the braking forces caused by regen are not under their control. This is why the regulations require that the braking system must be in control of all braking forces, including the braking forces caused by regen. And this is why regen must be turned off when these algorithms are activated, because turning regen off reduces the forces on the vehicle to the normal case for braking system forces only. This is the case for all vehicles having internal combustion engines, which is the case assumed when the algorithms were originally developed.

## VI. Loss of Regen While Going Over Bumps

Loss of regen while going over bumps happens in all electric vehicles, whether they are hybrid vehicles or battery-powered vehicles only. This loss of regen happens because regen is turned off by the ABS modulator to prevent forces on the vehicle not controlled by the braking system from interfering with the operation of the braking system's algorithms. A good example of this is found in several discussions of regen found on Tesla forums.

On one forum, the following discussion took place:<sup>41</sup>

Crebello

I've had my Model S 75 for 3 months now. Yesterday, I was approaching a red light with no one in front of me. I was far enough away that I let off the accelerator and let the regen kick in and slowed down. Then, when getting closer to the stop light, I started hitting the brakes (I drive like this every day with usually no issues). I hit a large bump in the road and for a second it felt like the car lost all regen and went into neutral. I was still on the brake pedal at this time but it definitely felt like the car went from slowing down to speeding up. ... This was the third time it's happened to me, all when coming to a stop and hitting a bump on the road. ... It scared the crap out of me and I know for a fact I was hitting the brake.

jordanrichard

I have had it where I hit a large bump and for a split seconds the traction control light came on. Any disruption to traction, or to wheels touching the ground or wheels stopping from moving, will cause weird things to happen. You know you hit a bump, but the car doesn't. It just knows that the wheels stopped moving & lost traction.

murphyS90D

Happens in my 2013 Ford Fusion Energi FWD when one front wheel goes over a sunken manhole cover. ... If either wheel is off of the ground, forward drive or regen braking is not possible because of the way a differential works. If your foot is not on the brake ABS is not going to intervene and stop the wheel that is off of the ground. It does feel like acceleration, but it is not. It is instantaneous removal of regen braking that makes it feel like acceleration.

Stiction

I used to go over a small speed hump at work under heavy regen and the rear wheels would chatter.

On another Tesla forum, the following discussion took place:<sup>42</sup>

gabeincal

I was in San Jose, getting off the freeway, [in preparation for] taking a left turn from the off ramp. I was doing about 25-30 mph when I got to the intersection. Cruise and autopilot were off. I had a green light, so crossed the intersection, and while crossing, started to brake. Hit a couple of uneven potholes in the intersection (it was a little rough to cross). While braking I felt a short bit of acceleration, like I left the cruise on or something similar, except my right foot was firmly (and only) on the brake pedal. ... I would swear that the car accelerated by about 5 mph in a very short period of time (probably a few tenths of a second). It felt like somebody punched the accelerator for me.

McRat

On many cars with regen and ABS, the ABS takes precedent. So when a wheel RPM drops rapidly without the others dropping, it shuts off the regen and kicks the wheel into ABS mode. It feels like the car is jumping forward, when all it really is, is the regen shutting off to allow the ABS to have full control of traction.

gabeincal

And that is what I was thinking. The ABS stopped the regen. This is possible, although I felt acceleration, rather than the lack of deceleration. And also, I felt no ABS 'play' on the brake pedal and no ABS or stability light came on ... But the potholes really might have something to do with what I experienced.

Logan5

I had a similar experience a few days ago. I was not coming off a highway, just a on a local road with autopilot off. I noticed I went over some uneven road when this incident occurred. ... Speed was about 20 MPH at the time.

McRat

You will often feel that 'kick' when you go over a wet manhole cover while decelerating, or over train tracks at an angle, or when two of your tires are in the middle of the lane where the oil/gravel normally exists. Wet leaves can do it, too.

Skipdd

I had the same thing happen and I posted about it. ... Like you, I called it into Tesla and gave them the time of occurrence. They confirmed it was ABS. Definitely freaked me out.

Finally, on a third Tesla forum the following discussion was found:<sup>43</sup>

EVSteve

For perspective, in a Volt an even more serious issue exists ... Applying the brakes first engages the regen braking, then progresses towards friction braking. ... The Volt disengages all regen braking if the system detects a skid or low traction. The gap between the loss of regen and application of the friction brakes is MASSIVE. The stopping distance in snow and ice is severely compromised and unpredictable. The only way to avoid this is to disable the regen system entirely by shifting to neutral and relying on the friction brakes.

Skotty

I think the correct solution is to have the anti-lock braking system also have control over regen. I would assume they already do in most cases. Hybrids have been using regenerative braking for many years, and should be subject to the same theoretical problem.

jerry33

Hybrids turn regen off whenever any of the braking safety systems engage (TC, VSC, ABS, etc.). I believe the Leaf does this, too.

These three discussions show that all Tesla vehicles can experience a loss of regen while going over bumps in the road, causing a feeling of momentary acceleration or lurching. This loss of regen is not a problem of poor blending of the brakes with regen. It is a problem because the vehicle and the user feel the total force on the vehicle at any given time. And when the total force changes because regen is lost, the vehicle and driver feel will feel this loss of regen as an acceleration or lurch. This change in deceleration is caused by the ABS system turning off regen when one wheel speed drops rapidly without the others dropping. It is not the result of a design decision made by Tesla, but of the algorithms in the ABS modulator that were designed by Tesla's brake supplier, Bosch. And Bosch designers had no choice but to turn off regen when their algorithms activate, because in order for their algorithms to operate properly, they must have control over all the braking forces on the vehicle while the algorithms are active. And, having no control over the regen magnitude, they must shut off regen while they are active. This is true for all other electric vehicles with regen also.

## **VII. Loss of Regen While Cornering**

Loss of regen while cornering also happens in all electric vehicles, whether they are hybrid vehicles or battery-powered vehicles only. The reason is the same as with loss of regen when going over bumps. It happens because regen is turned off by the ABS modulator to prevent

forces on the vehicle not controlled by the braking system from interfering with the operation of the braking system's algorithms. A good example of this is found in a discussion of the regen operation of the Ford Fusion hybrid found on the Ford Fusion Hybrid Forum. There, we find the following discussion <sup>Note5: 44</sup>

ACDii

“Slowing down from 35 or so and making a right hand turn, when on regen with the regen indicator on, part way through the turn the car feels as though it is slipping on ice. The regen stops for a brief moment ... Pretty sure it is tied into the steering position sensor ... When the regen braking acts normal the car slows as you step on the brake, with it slowing more the more you push the brake pedal. The amps are around -45 and dropping down as the car slows until I come to a stop at 100% ... When it is not acting correctly, and I press on the brake, the car slows a little, the regen indicator on, and the amps to the HVB are in the mid -50's, near -60. Yet, the car is not slowing down as it should, and I have to press harder on the brakes to slow it, engaging the pads instead before the car slows. There are times where I nearly miss my turn since the car is not slowing as expected ... Ford says the brakes [regen?] going away during a turn is normal ... I explained in detail that when slowing through a turn in regen only, when the steering wheel reaches the 90° mark past horizontal (1/4 turn), the regen stops braking for a brief instant making it feel like the car surges forward ... The problem can occur at any speed. Pulling into my driveway at under 20 MPH the car will skip when it happens. My driveway is gravel, so the sudden boost of the brakes going away is quite noticeable ... I mostly notice it when turning off a highway onto another highway, and all on right angle turns. There is one road that goes from 55 down to 40 and turns 90° left, then about a mile or so at 40 with a right 90° turn, and it happens at both turns regardless of speed. Of course, the faster the turn the more I notice it ... I did a reboot of the car, and while the brakes are now working like they should in a straight line braking, there is still the issue while turning.”

In response, Sleddog writes:

I can confirm there is definitely an issue with the regen brakes ... Pretty sure it is tied into the steering position sensor ... braking while turning. I can reproduce it, but only at speeds of less than 10 mph in a turn with light pressure on the brake pedal in regen mode when mechanical brakes are not active ... The drive system seems to be applying more torque to the inside wheel in the turn, over-powering the regen braking.

Then hybridbear adds some great observations<sup>44</sup>:

I measured this on my car [a Ford Fusion hybrid] ... [Figure 28] shows a chart of the vehicle speed and traction motor torque when this loss of regen happens while turning left. This happens on smooth road surfaces, so the loss is not due to bumps causing the loss of regen. I maintain steady [brake] pedal pressure throughout this whole braking event. You can see the motor torque [regen torque] drop off. This is when I feel a surge ... The regenerative braking will cut out under specific circumstances and the car will feel like it's lurching forward instead of slowing down. The situation is: braking using only regen brakes; no friction brakes; steady pedal pressure; going 15-20 MPH; turning the steering wheel at least 90 degrees left or right; driving on smooth pavement. Data I have logged from the Secondary On-Board Diagnostics Module C (SOBDMC) indicates that the traction motor briefly reduces its negative torque, which causes the car to surge forward. In one instance that I logged, the negative torque shows around 48 ft-lbs and then suddenly drops to about 8 ft-lbs. The traction motor then gradually increases the torque back to the appropriate level. In another instance, the negative torque suddenly went from about 28 ft-lbs to 8 ft-

---

Note 5. Extracts from several messages by the same contributor have been joined by ellipses in order to save space and to keep the discussion on topic. This has also been done for other contributors as well.

lbs. The drop in torque occurs in 1/10 of one second per my logged data. It takes about 2.5 to 3.0 seconds for the traction motor [regen torque] to return to the appropriate level of negative torque to stop the vehicle.

How sharp does the turn have to be and how fast to notice the problem? ... I'm not so sure that the steering wheel angle is all that important. I think it's more about the difference in wheel speed [Figure 29] I notice it most often when making left turns & slowing down, such as when turning into a parking lot or driveway. The lurch seems to happen between 15-20 MPH.

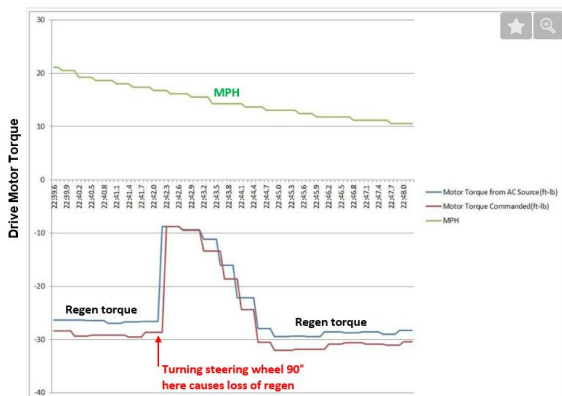

Figure 28. When the steering wheel is turned 90°, regen is lost and a forward surge is felt.<sup>44</sup>

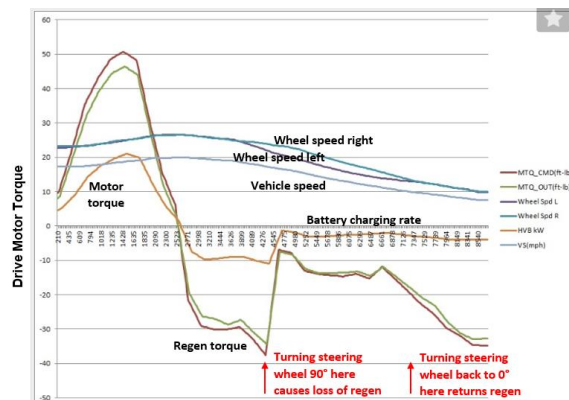

Figure 29. When the steering wheel is turned 90°, the wheel speeds change and regen is lost, causing a forward surge.<sup>44</sup>

When braking and turning, the "operating as designed" behavior appears to be when the difference in wheel speed reaches a certain threshold. The car then reduces regen braking & blends in the friction brakes. This transition should be seamless & imperceptible. Since our car had the 14S21 & 15E03 recalls completed, this transition has become perceptible. This is the issue. The car is "operating as designed" to reduce regen while turning. The problem is that there is now a momentary delay between when regen is reduced and when the friction brakes are engaged. There shouldn't be a delay. The transition should be smooth & unnoticeable. Had any of us noticed that regen braking goes away when turning before this? No, we hadn't. That shows that the transition was working properly for everyone in the beginning. It's only recently that these issues have begun to be reported.

Now, this loss of regen while cornering does not just happen on Ford Fusion hybrid vehicles. It also happens on Tesla vehicles. Here is a discussion of the regen operation of a Tesla Model 3 from the Tesla Motors Club Forum. There, a contributor named AltLogic writes:<sup>45</sup>

I drove my Model 3 down my local winding mountain road. My plan was to use [only] regenerative braking when entering the sweeping curves, and regenerative and friction braking [together] for the sharp turns. I noticed that when I turned the steering wheel the regenerative braking was reduced. As soon as I straightened the steering wheel, the regenerative braking would resume at full regeneration ... It was very obvious on corner exits. While in the turn there was very little if any deceleration. As soon as the steering wheel was close to straight there was an increase in deceleration.

Then #6DR61 responds:

I would expect this behavior. As far as I know, there is no system to detect frictional coefficient of the road surface & tire patch. So it is prudent to reduce load from regeneration on the drive wheels when turning with moderate lateral g forces.

Then #7Skidmark adds:

Mine does it too, but I have not seen it happen on an [Model] S/X. Going around a reasonably hard corner, regen pretty much turns itself off until the steering angle is reduced to a certain point. It is a bit disconcerting if you're not expecting it.

Then #8bXR140 responds:

Same thing happens on RWD [Model] S's too. Having all your braking at the rear of the car with high lateral load is a recipe for disaster. By turning off regen you're forced to use the actual [friction] brakes, which more proportionally load the car.

And #10bXR140 adds:

Yes. That's the way the S/X models work.

Finally, Skidmark sums up the discussion:

Yes, it [the turning off of regen during a turn] is definitely put in there to reduce the opportunity of rear-wheel traction loss leading to a spin. But, on the other hand, it also introduces a behavior of the car that could be very unexpected to a driver. The current behavior [turning off regen] is probably the lesser of two evils.

From these two discussions we see that all Tesla vehicles, as well as Ford Fusion hybrid vehicles, can experience a loss of regen while cornering. This loss of regen is caused by the ABS system turning off regen when the wheels on one side of the vehicle have a speed that differs from the wheels on the other side of the vehicle, which happens during cornering.. It is not the result of a design decision made by Tesla, but of the algorithms in the ABS modulator that were designed by Tesla's brake supplier, Bosch. And Bosch designers had no choice but to turn off regen when their algorithms activate, because their algorithms must have control over all the braking forces on the vehicle while the algorithms are active. And, having no control over the regen magnitude, they must shut off regen while their algorithms are active. This is true for all electric vehicles with regen, and not just Tesla for vehicles.

## **VIII. Explanation of EDR Data – The Cause of Sudden Acceleration**

We are now in a position to answer the questions about the EDR data posed in Section II. If we answer these questions in a slightly different order, it will help to better explain the events that happened.

1. Why does regen appear to be absent in the vehicle velocity data and the longitudinal acceleration data during the turn when the driver claims that the vehicle was in the HOLD mode at the time and the driver was not pressing on the accelerator pedal?

Answer: Even though the Model 3 is capable of regen at a speed below the 6 mph the vehicle was using during the right hand turn, regen appears to be absent in the EDR vehicle velocity data and the longitudinal acceleration data because regen was turned off by the ESP hev II module when the drive entered her turn. Turning off regen during a turn is the normal operation of a Model 3 Tesla, and of any electric vehicle with regen, because the ABS algorithms must know all the forces on the vehicle at the time the algorithms are time. But the algorithms can't know the regen forces because these forces are not controlled by the ESP hev II module. So the ESP hev II module has no alternative but to turn off regen.

We now skip to question 5, knowing there is little doubt from the steering wheel angle data and yaw rate data that the vehicle began to turn back to the left after initially turning to the right.

5. Why did the vehicle steer to the left as the motor speed increases, even though the driver was making a right hand turn?

Answer: The vehicle steered to the left because the increase in vehicle speed during a right hand turn created an oversteer situation to the right that caused the electronic stability control (ESC) function in the ESP hev II module to activate. The function responded by braking the outside front wheel to produce a counter-torque to reduce the oversteer to the right. Since the outer front wheel in this case is the left front wheel, braking it caused the vehicle to turn to the left as the motor speed increased.

We now pick up with question 2.

2. Why does the single rear drive motor speed increase at exactly the same time as the brakes are being applied?

Answer: This is because the Engine Drag Torque Control (EDC/MSR) function has been activated in the ESP hev II module as a result of sensing that a negative acceleration is being applied while in a turn. This negative acceleration is clear from the longitudinal accelerometer data. And we know that the EDC/MSR function is active at this time because it is the correct function to apply in this case, and because other functions in the ESP hev II module were active both before and after it became active. Therefore, it is only reasonable that some other ECP hev II module function should be active in the intervening time. (This is why we answered question 5 out of turn, so we could make this argument).

Now, the EDC/MSR function is intended to reduce negative acceleration caused by drag torque produced by an engine, or in this case, to reduce regen torque caused by the drive motor. It is not intended to reduce negative acceleration produced by friction braking. Therefore, it checks the brake light switch (i.e., the STOP lamp switch) to determine the cause of the negative acceleration. If the switch shows that the brake pedal is not being pressed, then it knows that the negative acceleration is caused by regen torque, and responds by sending a request to the drive motor to reduce the negative regen torque. This request continues until the negative regen torque is reduced to zero. However, if the switch check shows that the brake pedal is being pressed, then the EDC/MSR function does nothing, and another function in the ESP hev II module reduces the negative braking torque.

What likely happened in this incident is the brake switch was faulty. As a result, when the driver pressed on the brake pedal to cause a negative acceleration of 0.5 g's, the brake switch did not show that the brake pedal was being pressed. Therefore, when the EDC/MSR function detected the negative acceleration, it checked the brake switch to find the cause and got a false reading showing that the brake pedal was not being applied. As a result, it concluded that the negative 0.5 g acceleration was caused by a regen torque from the drive motor, instead of the brake system as was truly the case. This caused it to send a request to the drive motor to reduce the negative torque by increasing the drive motor torque. Since the drive motor torque was already zero because regen had been cut by the ESP hev II module early in the turn, this request to increase the drive motor torque caused the drive motor torque to increase from 0 to an RPM corresponding to 0.5 g's of positive torque. This is what we see in the longitudinal acceleration data, with a slight time delay of a few hundred milliseconds caused by the command latency over the CAN bus. What has happened in this case is that the faulty brake light switch has caused the brake pedal to behave like an accelerator pedal. The harder the brake pedal is pressed, the more positive drive motor torque is produced.

It is well known that brake light switches (i.e., STOP lamp switch switches) can have faults which cause the brake lights to fail to turn on when the brake pedal is being applied. There have been many recalls in the past for these faults, which have involved hundreds of thousands of vehicles over the past ten years or more. Appendix 2 lists many of these recalls by various vehicle manufacturers. From Appendix 2 it is obvious that this assumption of a

faulty brake light switch is a reasonable one that can be validated by experiment. It may also be pointed out that, although most brake light switches are dual redundant with one of the two switches turning ON while the other turns OFF, the EDC/MSR algorithm in this case may only check one of the two switches to make its decision. This may increase the likelihood for a brake switch fault that can cause a mistake in assessing the source of the negative acceleration.

3. If the driver had her foot on the brake pedal to cause the -0.5 g longitudinal acceleration, then how could she also have pressed on the accelerator pedal at the same time to cause the drive motor to speed up? Tesla has stated many times in writing that when the accelerator pedal and the brake pedal are pressed at the same time, the brake pedal always wins. Therefore, the speeding up of the drive motor cannot be due to the driver pressing on the accelerator pedal, and must have been caused by the vehicle itself.

Answer: From the answer to question 2, it is clear that the driver did have her foot on the brake pedal and that pressing on the brake pedal was one of the reasons that the car drive motor sped up to produce the sudden acceleration. The primary cause, however, for the sudden acceleration was a fault in the brake switch that caused the EDC/MSR function to misinterpret the negative acceleration as coming from the drive motor instead of the brake pedal.

4. Why does the drive motor speed remain high and the vehicle continue to accelerate forward even after the accelerator pedal reading has decreased back to zero?

Answer: The drive motor speed remains high even after the accelerator pedal reading has decreased back to zero because the EDC/MSR function normally keeps applying the compensating torque even after the original negative drag torque has been reduced to zero. This is how the EDC/MSR algorithm works as discussed in Bosch patent DE10238224B4 mentioned in Section IV. This behavior is intended because the EDC/MSR function is most often used while negotiating a curve on a highway at higher speeds. The delay allows the vehicle to exit the curve before the positive acceleration is removed, which is good driving practice.

6. Why does the EDR data show that the brake pedal was not pressed even though the driver maintains that she did press the brake pedal and even though Tesla's letter based on the high resolution log data agrees with the driver?

Answer: The EDR data shows that the brake pedal was not pressed because the brake light switch was faulty. The driver did actually press on the brake pedal as the driver maintains and as Tesla agrees in a letter to the driver. This conclusion verifies the assumption made in the answer to question 2 that the brake light switch was faulty.

7. If the driver never pressed the accelerator pedal, then why does the EDR data show that the accelerator pedal was pressed?

Answer: Most people have 100% confidence that if the accelerator pedal data is non-zero, then the driver was pressing on the accelerator pedal instead of the brake pedal. For them, this is the cause of all alleged incidents of sudden acceleration. Yet, in this incident the EDR data shows that a negative 0.5 g longitudinal acceleration was detected by an accelerometer, which could only have been caused by the driver pressing on the brake pedal, because this acceleration exceeds the maximum regen acceleration of a negative 0.3 g. And simultaneous with the negative 0.5 g acceleration, the EDR data shows the accelerator pedal data becoming non-zero, which would produce a positive longitudinal acceleration. Therefore, the driver's foot had to be on the brake pedal at the same time the accelerator pedal data became non-zero. How is this possible?

To answer this question, let's first clarify what was happening in greater detail. Figure 30 shows the sequence of events involved in this incident. The driver's foot could either be on the brake pedal or the accelerator pedal, and not on both at the same time. This explains the exclusive-OR (XOR) function in Figure 30. Pressing on the brake pedal produced a negative acceleration of 0.5 g's which was recorded by the longitudinal accelerometer. The EDC/MSR algorithm in the brake modulator also detected this negative acceleration, and after checking the defective brake light switch, it interpreted the negative acceleration as a drive motor drag torque. Therefore, it issued a request to the drive motor for a positive motor torque to offset the negative drag torque. This request went via a CAN bus to the VSC input of the Vehicle Torque Command Generation Function in the drive motor control system (Figure 16), where it became a positive torque request to the drive motor torque map.

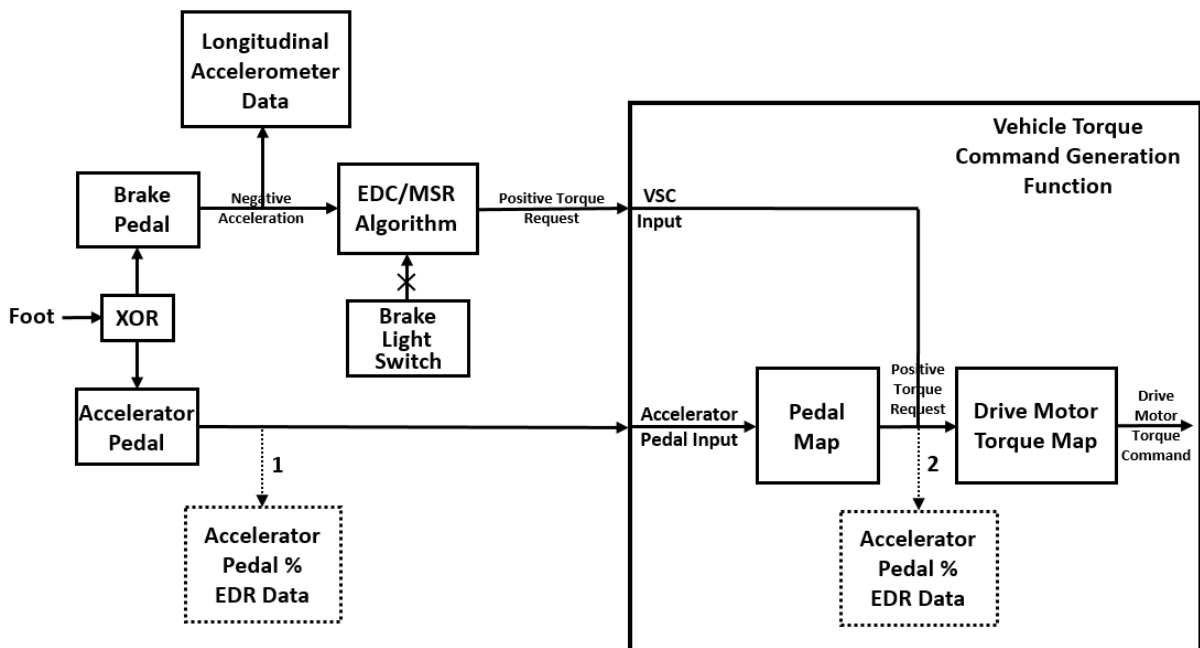

Figure 30. Sequence of events involved in this incident

Given this sequence of events, the question being asked now is: If the driver never pressed on the accelerator pedal, then why does the EDR data show that the accelerator pedal was pressed in this incident? If the accelerator pedal EDR data is obtained from position 1 in Figure 30, as most people would believe, then non-zero accelerator pedal data makes no sense because the accelerator pedal was not pressed. Therefore, it should remain zero, causing a contradiction of the EDR data in this incident. On the other hand, if we believe that the non-zero accelerator pedal data from position 1 is correct, leading us to believe that the accelerator pedal was pressed, we have no explanation for how the negative 0.5 g acceleration was produced that was recorded by the longitudinal accelerometer.

An alternative explanation for the non-zero accelerator pedal data in this incident is that the accelerator pedal data is really obtained from position 2 in Figure 30. This would produce non-zero accelerator pedal data either when the accelerator pedal is pressed or when a positive torque command is issued by the EDC/MSR function. And position 2 is completely in accordance with NHTSA's regulation on the origin of the EDR accelerator pedal % data because the regulation allows either the accelerator pedal position data or the throttle position data to be recorded for the accelerator pedal % data in an internal combustion engine. If the source of the EDR accelerator pedal data is from position 2 in this incident,

there is no contradiction of the EDR accelerator pedal data with the longitudinal accelerometer data in this incident, and the explanation given in this paper for the sudden acceleration remains valid.<sup>Note 6</sup>

8. Why does the EDR data show that the ABS system did not engage when both the accelerometer data and Tesla's letter based on the high resolution log data verify that the ABS system did engage?

Answer: The term "ABS system" can have two meanings. In some cases, it can mean the ESP hev II module and all its incipient functions as listed in Section IV. In other cases, it can mean only one of the functions included in the ESP hev II module; namely the ABS function that produces an ON/OFF modulation of the braking force to prevent wheel lock-up in the presence of slip. It is believed that this latter meaning applies to the ABS activity indicator logged by the EDR system. If this is the case, the EDR data indicating that the "ABS system" failed to engage is correct, meaning that the ABS algorithm with ON/OFF modulation did not activate. However, other functions of the ESP hev II module could still activate, and certainly did, such as the ESC function, the EDC/MSR function, and possibly the Corner Brake Control (CBC) function. Whether the warning light for the ABS system engaged or did not engage is an interesting piece of information. But it is not critical to an understanding of what happened during this event. What is more critical to know is that three ESP hev II module functions did activate during this incident.

We have now answered all of the questions posed by the EDR data. This was done using only one assumption; namely, that a defect in the brake light switch caused the EDC/MSR function in the ESP hev II module to make an incorrect decision about the origin of the negative acceleration it encountered, causing the EDC/MSR function to issue a request to the drive motor for a large positive torque. This assumption is supported by: 1) the EDR data that shows that the brake pedal was not pressed even though the driver maintains that she did press the brake pedal and even though Tesla's letter based on the high resolution log data agrees with the driver, which proves that the brake switch was defective, and 2) Appendix 2, which gives specific information on recalls for defective brake light switches that have affected hundreds of thousands of passenger vehicles from nearly every manufacturer over the past ten years. If this explanation of our original sudden acceleration incident is correct, it should also explain other Tesla sudden acceleration incidents. Let's now check the descriptions of other Tesla sudden acceleration incidents to see if our explanation can apply to them also.

### **IX. Application to Other Tesla Sudden Acceleration Incidents**

Appendix 3 lists 102 Tesla sudden acceleration incidents reported to NHTSA over the past seven years. These incidents were obtained from a legal brief for a Class Action Suit on Tesla Sudden Acceleration filed in a California court entitled Lee v. Tesla Inc, dated Jan 20, 2020.<sup>46</sup> The incidents have been divided into three categories:

- A. Incidents starting while slowing down with turning to park or while accelerating with turning to leave a parking position (70 incidents),
- B. Incidents starting from a stationary position (27 incidents), and
- C. Incidents starting at high speed (5 incidents).

The descriptions of the incidents omit all information about dates, locations, injuries, vehicle damage, and follow-on communication with dealers and Tesla, leaving only information about

---

Note 6. Tesla Inc should be required to furnish a circuit diagram showing the origin of the EDR accelerator pedal data. If the origin of the data is position 2 as shown in Figure 30, then this could explain a lot of Tesla sudden acceleration incidents in which the drivers maintained that they did not press on the accelerator pedal while Tesla cites non-zero EDR accelerator pedal data to prove that they were wrong.

the incidents themselves. This was done to save the reader's time, and to help the reader to see similarities between the incidents.

By reading the descriptions in Category A, one can see that they are very similar to the incident described in Section II of this paper. They involve a driver slowing down while making a turn in preparation for either: a) parking in a perpendicular parking spot, b) driving into a driveway prior to entering a garage, c) turning on a circular street, or d) turning a street corner. In all of these cases, the driver can be expected to have his/her foot off the accelerator pedal and ready to apply the brake pedal during the turn, with actually applying the brake pedal near the end of the turn. Therefore, the explanation in this paper should apply to all of the cases in Category A, which is about 70% of all Tesla sudden acceleration cases. The same explanation should apply to Model S and Model X Teslas as well as Model 3 Teslas because all three models use the same Bosch braking system and the same Tesla design for the drive motor controller.

If we read the descriptions in Categories B and C, however, we find that they differ from the incident that produced our explanation. They involve no slowing down while turning, and originate instead from either a stationary position (Category B) or while driving at a high speed (Category C). Therefore, our explanation should not apply to these two categories, which represents about 30% of all Tesla incidents. As a result, there might be more than one cause of sudden acceleration in Tesla vehicles.

In the case of Category C incidents, one possible additional cause might be some malfunction of the autopilot software, which could use the cruise control pathway to increase the drive motor torque without the driver's intervention. Some drivers have even speculated that their incidents were caused by this explanation.

In the case of Category B incidents, it may be possible that some other braking function can affect the drive motor torque using the same electrical pathway from the braking system to the ESC input of the Vehicle Torque Command Generation function, to the drive motor torque map as shown in Figure 30. For example, a self-test function in the braking system might generate a false torque request signal to the motor torque map. Such a self-test function is likely to be performed while the vehicle is stationary with no foot on the brake pedal. But it may also take place with a foot on the brake pedal if a faulty brake pedal switch is indicating there is no foot on the brake pedal.

In summary, our explanation for sudden acceleration in this incident may apply to about 70% of all Tesla sudden acceleration incidents, which is a pretty good result. But further work is required to explain the remaining 30%.

## **X. Application to Other Electric Vehicles**

The first step in assessing how our explanation for sudden acceleration can apply to other electric vehicles was to find out what braking system is used in each vehicle. This was done because our explanation states that the cause of sudden acceleration in this case lies in the EDC/MSR function of the brake system and how it is confused by a fault in the brake light switch, and not in the drive motor control system. Therefore, if other electric vehicles use the same Bosch braking system, we might expect similar sudden acceleration incidents to occur in other electric vehicles as well.

Table 1 shows the results of our search on the braking systems of other electric vehicles. The results are astonishing. Nearly every electric vehicle on the market today uses the Bosch iBooster with the Bosch ESP-hev II brake module, which is exactly the same Bosch braking system that is used by Tesla. This may come as no surprise because the Bosch iBooster allows a lower vehicle assembly cost than a conventional vacuum modulator. And the Bosch ESP-hev II module allows better blending of the friction brakes with the regen function under the control of software written by the vehicle manufacturer. But Bosch has sweetened the deal even further

by creating a world-wide manufacturing capability for their braking system with plants in China, Mexico, and Germany, and by providing engineering support to vehicle manufacturers with over 2000 application engineers who can work in the manufacturers' plants to assure successful brake system integration. Meanwhile, other brake system suppliers like TRW/ZF have delayed their offerings for electric vehicles due to investment problems associated with restructuring in the world market.

Table 1. Brake systems used in electric vehicles on the market today

Manufacturer	Models	OPD	RWD Only	AWD	FWD Only	SUA Incidents	ABS System & Manufacturer
<b>BEV's</b>	Battery EV's						
Tesla	All models <sup>1</sup>	Yes	Yes	Yes	---	Yes	Bosch ESP-hev II, iBooster
BMW	i3 <sup>5</sup> , iX3	Yes	Yes	---	---	Yes	Bosch ESP-hev II, iBooster
Jaguar (Tata)	i-Pace SUV	Yes	---	Yes	---	Yes	Bosch ESP-hev II, iBooster
Mercedes	B-Class <sup>4</sup>	Yes	Yes	Yes	---	Maybe	Bosch SBC Bosch ESP-hev II, iBooster
Volkswagen	ID.3 (MEB kit) <sup>5</sup>	Yes	Yes	Yes	---	---	VW eBKV Bosch ESP-hev II, iBooster
Audi	R8 e-tron	No	Yes	Yes	---	Yes	VW eBKV Bosch ESP-hev II, iBooster
Porsche	Taycan	No	Yes	Yes	---	---	Bosch ESP-hev II, iBooster
MiniCooper	Countryman ALL4		---	Yes	---	---	?
Chevrolet	Bolt <sup>5</sup>	Yes	---	---	Yes	---	Bosch ESP-hev II, iBooster
Nissan	Leaf	Yes	---	---	Yes	---	Hitachi
Fiat Chrysler	500e	Yes?	---	---	Yes	---	Bosch ESP-hev II, iBooster
Volkswagen	e-Golf (MQB kit)	No	---	---	Yes	---	VW eBKV Bosch ESP-hev II, iBooster
Hyundai	Kona, Ioniq	Yes	---	---	Yes	---	Hyundai iMEP
Honda	Clarity	No	---	---	Yes	---	Bosch ESP-hev II, iBooster
Kia	Niro	Yes	---	---	Yes	---	Bosch iBooster?
Nio	ES6	No		Yes	No	---	Bosch ESP-hev II, iBooster
Rivian	R1S SUV			Yes		---	Bosch ESP-hev II, iBooster
<b>ICE Hybrids</b>	With power split						
Toyota	Prius hybrid synergy		---	---	Yes	Yes	Toyota Advics
Ford	C-MAX hybrid HEV C-MAX Energi PHEV		---	---	Yes	Yes	TRW/ZF IBC
Chevrolet	Volt		---	---	Yes	---	ZF IBC Bosch ESP-hev II, iBooster
Cadillac	CT6 PHEV		---	---	Yes	---	Bosch ESP-hev II, iBooster
Audi	A3 e-tron PHEV		---	---	Yes		VW eBKV w/TRW ESP Bosch ESP-hev II, iBooster

This table shows two other pieces of information in addition to the braking system used, namely: 1) whether the vehicles use rear wheel drive (RWD), front wheel drive (FWD), or both

front and rear wheel drive (AWD), and 2) whether sudden acceleration incidents have been claimed in each vehicle. The drive wheel information was included because it is believed that the EDC/MSR function is more likely to be used by vehicles having rear wheel drive (either RWD or AWD) than by vehicles having front wheel drive (FWD). This belief appears to be true, because the only battery vehicles (BeV's) that have had sudden acceleration incidents to date are those with rear wheel drive (either RWD or AWD). Some hybrid PHEV vehicles with front wheel drive (FWD) have had sudden acceleration incidents, but this may be the result of the ICE engine in the PHEV causing the problem, and not the braking system.

Therefore, this table shows that all battery-powered electric vehicles (BeV's) are susceptible to sudden acceleration if they have: 1) a Bosch braking system, 2) rear wheel drive (either RWD or AWD), and 3) defective brake light switches. Let's take a look at some of the sudden acceleration incidents that support this conclusion.

Figures 31 and 32 show a BMW i3 that has run into a wall.<sup>47</sup> This incident took place in the Kiamuki Shopping Center in an inner suburb of Honolulu on August 11, 2019. Although no driver's testimony is provided about the incident, it is clear from the photos what happened. The driver was trying to park in a perpendicular parking space in preparation for shopping in the Times supermarket. The parking space was near the entrance of the supermarket. As the driver was pulling into the parking space after making a 90° turn, the vehicle's drive motor revved up. The BMW i3 has a single rear drive motor just like many Tesla's. This incident is exactly like the 70 Tesla sudden acceleration incidents of Category A in Section 9, for which our explanation is valid.

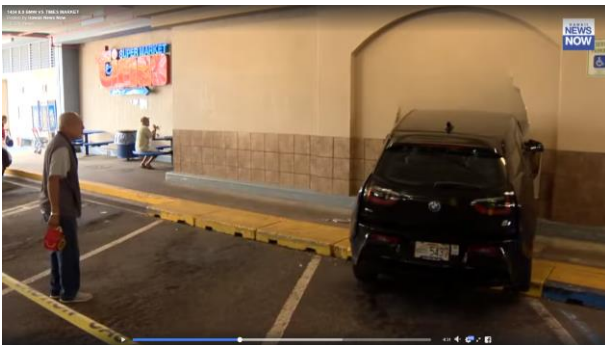

Figure 31. BMW i3 after suddenly accelerating while pulling into a perpendicular parking space.<sup>47</sup>



Figure 32. Side view showing damage to the wall behind the parking space. Store entrance is in the background.<sup>47</sup>

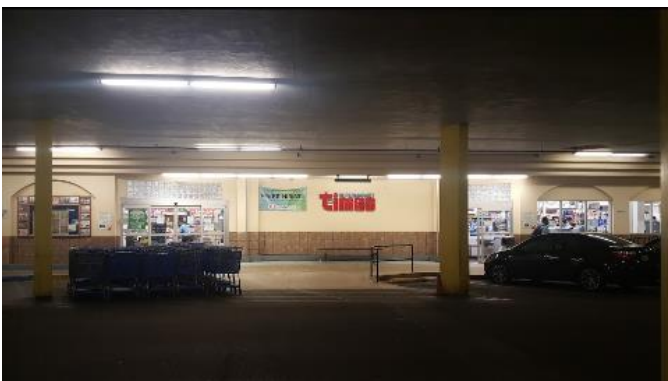

Figure 33. Store entrance near parking space. The parking space with the BMW i3 is to the left.



Figure 34. Close-up of store entrance showing the name of the supermarket.

The news article mentions that this was the second such incident involving a BMW i3 in the Honolulu area recently.

A third BMW i3 sudden acceleration case is provided by a woman named Alexandra Briseno in California who writes:<sup>48</sup>

“I purchased a BMW i3 in my home state of California on August 21, 2016. Between August 21, 2016 and May 7, 2017, we experienced 3 episodes of sudden acceleration. All 3 episodes occurred split seconds before the car was to make a complete stop. The 1st incident occurred when my husband was attempting to park the car in our driveway. The 2nd incident occurred just as I was coming to a complete stop at a traffic light. And the 3rd incident occurred just as I was parking the car against a street curb.

The 3rd incident was the scariest because the sudden acceleration propelled my car to:

1. Collide with my tall SUV, (fortunately no visible damage because I hit the SUV's tire) and then
2. Hit the street curb, jumped over it, and finally came to a
3. Stop just inches away from striking my husband and our small dog”.

The interesting thing about these three BMW i3 incidents is that they are exactly like the 70 Tesla sudden acceleration incidents of Category A in Section 9, for which our explanation is valid. Yet, the BMW i3 drive motor control system uses completely different hardware and software than the Tesla drive motor control system. This is strong evidence that the BMW i3 incidents are caused by the Bosch braking system, which is identical in the Tesla and BMW i3 vehicles.

The parallels between the BMW i3 and all Tesla vehicles run even deeper when regen is considered. Included here are two short articles by an experienced automobile columnist who discusses regen in the BMW i3, which the reader can compare to discussions of the Tesla in Sections VI and VII.

**“Living with BMW i3: After 2,000 Miles – Dislikes”** by Tom Moloughney June 23rd, 2014<sup>49</sup>

**“Regen Braking is Less Aggressive.** Before I start complaining, let me say that I’ve driven just about every modern electric vehicle and plug-in-hybrid and I believe the BMW i3 has absolutely the very best regenerative braking system on the market. Tesla probably comes in second and the Volt, when driven in low mode, is right behind the Model S. BMW dialed back the regen on the i3 a bit, probably in the vicinity of about 10% when compared to the ActiveE. People who never drove the ActiveE or MINI-E won’t understand what I’m complaining about because the i3’s regenerative braking is still strong and very smooth. It can bring the car to a stop without using the friction brakes faster than any regenerative braking system on any other EV will. Still, I liked it stronger like it was on the ActiveE and MINI-E. I guess regenerative braking is like coffee. Some will prefer the Blonde Roast with cream while others want the Dark Roast served black. Give me my regen as strong as possible please. I recommended to BMW that they offer different regen settings and let the customer decide how strong they like it, but that didn’t come to pass on the i3. It’s still very good, and integrates seamlessly when decelerating. I would just prefer it a bit stronger.

When I navigate this bend in the road by my house, the regenerative braking disengages. Since the road is also downgrade I find I have to use the friction brakes to keep from accelerating down the hill. I didn’t have to do that in the past while driving my MINI-E or ActiveE as both would allow the regenerative braking system to hold back the car during turns like this.

**Regen Braking Disengages During Hard Turns.** I’m a little surprised with the second complaint I have with the regenerative braking. While negotiating turns, the regen sometimes disengages which will give the sensation that the car is actually speeding up. Of course it isn’t (unless you are going downhill), but when you are in full regen and it suddenly disengages, it

does feel like the car is accelerating when in fact it just isn't being slowed down by the regenerative braking. During the MINI-E and ActiveE programs, I personally spoke to dozens of people who contacted me asking if my car ever suddenly surged ahead. What was happening with those cars was different though. If the regenerative braking system was operating and the car hit a pothole or a bump that caused the wheels to lose traction, the traction control would disengage the regen in an attempt to prevent the loss of control. When this happened, it would give the driver the sensation of sudden acceleration, especially when driving downhill. This was unsettling if you didn't understand what was happening and typically when this happened the owner would take the car to the dealer for service. The dealer would look it over and find nothing wrong and give it back to them. Frustrated, many of the drivers then contacted me to ask if anyone else had complained of this sudden acceleration problem. After explaining what was actually happening to them they understood what was going on. I would also caution them to always have their foot ready to press the friction brake when they were using regen to slow the car down, especially if they were approaching the car in front of them as they were decelerating.

BMW has indeed improved the whole traction control/regenerative braking system communication and the i3 performs much better than the MINI-E or ActiveE did when the tires lose traction during regenerative braking. However it now disengages during cornering, and neither of its predecessors ever did this. I can tell by how it's working that it isn't a flaw in my system. It was intentionally designed to do this, perhaps to prevent the thin tires from losing traction while negotiating hard turns. Again, it's not a problem as long as you know it's going to happen and you are ready to use the friction brakes if necessary. I've found it mostly happens while I'm taking a highway off-ramp that circles down under the highway overpass. It seems the speed I'm traveling combined with the sharp, constant turn is too much and the traction control preemptively disengages the regen in an attempt to prevent the loss of traction. I believe this is something the dealers need to communicate to the customer. It can be a safety issue if new i3 owners aren't prepared for it. Just like with the MINI-E and ActiveE, I'm certain there will be customers that believe there is something wrong with their car and will take it to the dealer for service. And just as I'm sure that will happen, I'm sure the service departments won't have a clue what the customers are talking about and will tell them they checked it out and car is fine. Unless the service manager happens to read this post."

"BMW i3 Sport One-Month Review" by Tom Moloughney <sup>50</sup>

**"Regen Braking Over Bumps and in Turns Fixed in i3 Sport.** In the i3 Sport, BMW has improved the i3's traction control system, claiming it is now 50 times faster than before. I don't know how to quantify the 50 times faster claim, but I can absolutely feel the difference and it's definitely much better. My previous i3 would disengage the regenerative braking if I hit a bump in the road and the car lost a little traction. Evidently, if the traction control detected any kind of slippage it would turn off the regenerative braking, so as to not lose complete control. This would give i3 owners the sensation that the car was actually speeding up after hitting a bump if they weren't accelerating or coasting when they hit the bump.

I personally had to explain what was happening to many i3 owners that reached out to me because they thought there was something wrong with their car. Additionally, the car would gradually decrease the level of regenerative braking in curves, as the traction control would work to prevent slippage. While taking exit ramps at highway speeds, my car would completely cut the regenerative braking out if the turn was sharp.

That doesn't happen with my i3 Sport. The regenerative braking remains active when I go over bumps and momentarily lose some traction, as well as when the car is taking curves at high speeds."

From these articles the reader can see that regen in a BMW i3 behaves much like regen a Tesla. We now know that this regen stopping behavior is a product of the common Bosch braking system that shuts off regen when wheel slip is detected, and not of the different drive motor control systems. The reader can also see from the highlighted text that the EDC/MSR function is working properly to reduce regen in curves because the brake light switch is working normally in this case.

## **XI. Application to ICE Vehicles**

The Bosch ESP-hev II module used in electric vehicles is the ninth version of a modulator module originally designed for vehicles with internal combustion engines (ICE). It was modified for electric vehicles by changing two hydraulic valves and possibly adding an electronically controlled plunger mechanism. But the slip control functions remained unchanged. Therefore, these slip control functions, and specifically the EDC/MSR function, will operate the same way in an ICE vehicle as they do in electric vehicles. It doesn't matter if the drag force is provided by an ICE engine or by an electric motor in regen. If the EDC/MSR function detects a drag force while slip is occurring, it will send a request to the ICE engine to increase its torque in order to reduce the drag torque, which will reduce the wheel slip and keep the vehicle stable. This is how the EDC/MSR function is supposed to work. But if the brake light switch is defective, the EDC/MSR function will confuse a brake-induced deceleration for an ICE-induced drag force, and send the ICE engine a request to increase its torque in response to pressure on the brake pedal. The result is that the vehicle will accelerate in response to the driver pressing on the brake pedal, which the driver interprets as sudden acceleration. Unfortunately, when the driver tries to explain this unusual situation to others, they invariably accuse him of "stepping on the accelerator pedal instead of the brake pedal". This accusation is especially effective in courts of law when manufacturer's attorneys tell the judge and jury that the only way the vehicle can speed up is to step on the accelerator pedal. So the driver must have been confused.

ICE vehicles that are most susceptible to this sudden acceleration mechanism are vehicles with rear wheel drive, which includes nearly all pickup trucks and luxury sedans, but also some sport vehicles such as two-door coupes. In case the reader still finds it difficult to believe that this EDC/MSR function can cause sudden acceleration in ICE vehicles, he is asked to read a paper by the author entitled "Unintended Acceleration with a Confirmed Cause – Smaller Tires in Front", which is caused by this same EDC/MSR function.<sup>51</sup>

## **XII. Comments on Testing**

In the event that a sudden acceleration incident occurs in which the driver claims that the vehicle accelerated while his/her foot was pressing on the brake pedal, the following tests should be performed:

1. Check the OBDII port to see if any DTC codes were set for a bad brake light switch.
2. Check the EDR summary to see if the ABS warning light was off during the incident. The ABS function is likely to have been turned OFF by a defective brake light switch.
3. Test the brake light switch for proper electrical operation of both switches.
4. If the vehicle is still intact, operate the vehicle in the same manner it was being operated during the incident to see if one can reproduce the sudden acceleration.

If one is trying to induce sudden acceleration on a vehicle that has not experienced sudden acceleration by making the brake light switch defective before testing the vehicle while stopping, be aware that some methods of generating brake switch faults may be incompatible with the operation of the brake functions you are trying to test as a result of built-in test functions. It may require some experimentation to produce the correct fault.

### **XIII. Summary and Conclusion**

The EDR log data from a Tesla sudden acceleration incident has been analyzed. To explain the EDR data, the operation of Tesla's drive motor control system and braking system were examined. As expected, friction braking and regen operation are completely separate with no blending, with the possible exception of Tesla models having a single rear drive motor. The braking system, however, also includes several vehicle stability control functions that can have a profound effect on regen operation in the presence of wheel slip, such as stopping regen when going over bumps and while turning corners. One of these slip control functions called Electronic Drag Control (EDC/MSR) can even cause the drive motor to speed up if regen is causing slip in the rear drive wheels that can lead to an oversteer or understeer. This same slip control function can be misled by a defective brake light switch to confuse a brake-induced deceleration for a regen-induced deceleration, in which case as the driver presses harder on the brake pedal, a larger positive motor torque is produced. This is believed to be the cause of sudden acceleration in the incident under consideration. To see if this same mechanism could explain other Tesla sudden acceleration incidents, NHTSA contact reports were examined. It was found that over 70% of all Tesla sudden acceleration incidents could be explained by this cause. Similarities between the braking systems for Tesla and non-Tesla vehicles imply further that this same cause can explain many sudden acceleration incidents in non-Tesla electric vehicles having rear-wheel drive (RWD) or all-wheel drive (AWD). Finally, it is concluded that vehicles having internal combustion engines along with rear wheel drive are susceptible to sudden acceleration from this cause if the brake lights are defective. Comments for testing vehicles for this mechanism are provided.

### **XIV. Acknowledgements**

The author would like to thank the driver named ABHAR on the Tesla Motors Club forum for her foresight and determination in obtaining the EDR data and for providing it to the author. Few sudden acceleration victims are willing to spend the time, effort and money needed to find the cause of their incident. But this data was essential for determining the cause of sudden acceleration in this case. Without her initiative, this study would not have been possible.

## Appendix 1. Bosch iBooster

The Bosch iBooster has several advantages over a traditional vacuum booster that make it the booster of choice for any electric vehicle manufacturer, whether it be Tesla or any other manufacturer of a battery or hybrid vehicle on the market. These advantages include, in descending order of importance:

- 1) Electronic sensing of the brake pressure & brake pedal position. Electronic sensing allows better blending of regen with the friction brakes for vehicles having either front wheel drive or rear wheel drive, or with regen on the accelerator pedal or on the brake pedal. With more electric vehicles entering the market, regen will become more widely used, and more manufacturers will desire either the iBooster or one of its competitors.
- 2) Cheaper to assemble an electric vehicle because no vacuum source is required, either from an engine manifold or an external vacuum pump. This means fewer parts at the vehicle level and simpler assembly operations in which electrical connections replace vacuum plumbing connections, both of which lead to lower vehicle production cost.
- 3) Software adjustability of booster operation by the vehicle manufacturer, including the jump-in value and the boost value. This allows the vehicle manufacturer to tailor the stopping performance and pedal feel for different driving scenarios even after vehicle is manufactured. This variability is not required for good braking performance, but helps to sell the electric booster to vehicle design engineers who can pass it along if they desire to vehicle buyers as a driver-selectable braking feature.
- 4) Smaller physical size than vacuum boosters having a large vacuum diaphragm. This allows more room under the hood for other components, which provides greater vehicle design flexibility. .
- 5) Faster operation than a vacuum booster. This is a bonus feature that enables shorter stopping distances than a vacuum booster. But vacuum boosters have not had a safety problem with stopping distance to date, so its improvement may have little effect on safety statistics.
- 6) Maintains hydraulic control by the driver in the event of booster failure. This is a necessary safety feature that is found in vacuum boosters also. So it is not really an advantage over vacuum boosters, but merely eliminates a possible safety concern.

The iBooster has the following disadvantages, which are considered relatively minor by most manufacturers:

- 1) The iBooster is more expensive than a vacuum booster. This is because an electric motor with its associated gearing, sensors, and electronic PID controller with output drive transistors is more expensive than a vacuum diaphragm. But this higher cost at the component level is offset by a lower assembly cost at the vehicle level.
- 2) The maximum boost of the iBooster is limited by the electric motor torque (a motor design feature) and the motor current (a 12V battery & wiring feature). The boost of a vacuum booster can also be limited by the diameter of its diaphragm, which is solved by replacing it with a larger diameter diaphragm. The same problem in the iBooster is solved by substituting a more powerful electric motor when additional torque is needed. Bosch can supply the iBooster with four different electric motors to provide the proper torque for any given vehicle need.
- 3) If the 12V battery or 12V DC/DC converter dies, then brake boost dies with it. This is an unavoidable problem that is mitigated by the ability of the booster to maintain hydraulic control of the brakes with the driver supplying the required braking force. But boost will be lost if 12V power is lost, making it more difficult for the driver to stop the vehicle. The government places a limit on the brake pedal force that the driver

must provide in order to stop safely when this occurs, so this controls the mitigation of a 12V power loss.

Bosch sells the iBooster to vehicle manufacturers as a user-programmable unit. The iBooster translates the brake pedal force applied by the driver into hydraulic pressure on the brake fluid in the tandem master cylinder (TMC), which is the same hydraulic pressure provided to the brake pads. When the brakes engage, the driver feels a return force on the brake pedal that gives him a certain feel for how the brakes are being applied. This feel is affected by the transfer function for how the brake pedal force is changed onto TMC pressure to the brakes, where the TMC pressure is directly proportional to the vehicle deceleration designated by the letter  $z$ . Figures 35 and 36 show how this transfer function can change as different parameters are adjusted by software programming.

Figure 35 shows three different transfer functions; a) a gradual one labeled “Sport”, b) a rapid one labeled “Comfort”, and c) an in-between one having no label. The in-between one is shown with a hysteresis that gives it a slightly different transfer function during brake engagement than during release. The other two transfer functions have a similar hysteresis behavior. The three transfer curves are distinguished by having different values of the same adjustable parameters labeled by the circled numbers in Figures 33 and 34. These parameters will now be discussed.

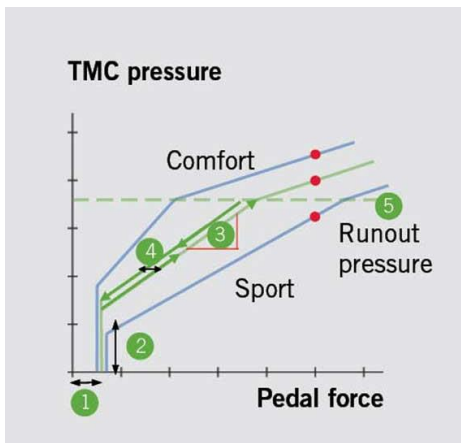

Figure 35. iBooster TMC pressure versus pedal force showing three possible transfer curves.<sup>52</sup>

Adjustable parameters for customized pedal feel		
	Base design (HW)	Adjustable (SW)
1 Cut-in	✓	
2 Jump-in	✓	✓
3 Boost ratio	✓	✓
4 Hysteresis	✓	✓
5 Runout pressure	✓	✓

Figure 36. iBooster parameters software adjustable to vary the pedal feel. Circled numbers indicate transfer curve properties shown in Figure 35.<sup>52</sup>

The cut-in parameter determines the “play” in the brake pedal, which is the amount that the pedal must be pressed before the driver feels a return force. If this value is too high, the driver feels that brake operation is delayed, giving an uncertain feeling that the brakes may not be working properly. If the value is too low, then the brakes may be applied at all times, causing undue wear on the brake pads. This parameter is not software programmable in the iBooster, but may be adjusted by changes in the mechanical linkage between the pedal and the piston in the master cylinder.

The jump-in parameter determines the force on the brake pads when they are initially applied, which determines the force the driver feels on the brake pedal. If the jump-in value is too low, the driver doesn’t feel the brakes coming on, and therefore thinks they may be defective. If the jump-in value is too high, the driver feels that the brakes are “grabbing” and thus thinks the brakes are too sensitive. During a parking maneuver, it is better to have a small jump-in value to allow easier maneuvering. Sport drivers also like to have a low jump-in value because it gives them finer modulation of the braking force during various racing maneuvers, like when entering and exiting turns. But during panic braking, it is better to have a high jump-in value for faster brake application. Jump-in is a mechanical feature than cannot be eliminated in conventional

vacuum boosters because it is a feature determined by mechanical tolerances, making it difficult to control within fine limits. Electric boosters allow software control of the jump-in value, and designers usually try to adjust it to give the same feel that conventional vacuum boosters have provided for drivers over many years.

The boost ratio is the slope of the boost curve, or the change in pressure to the brake pads with a change in pedal force. This is not the same as the boost magnitude, or merely boost, which is the ratio of the instantaneous brake pressure to the instantaneous pedal force. Boost ratio is the rate at which boost is applied, which determines how rapidly the brake pressure changes with pedal force, or how easily the brake force can be modulated. Sport drivers like to have a low boost ratio because it gives them finer modulation of the braking force during various racing maneuvers, like when entering and exiting turns. Most ordinary drivers, especially shorter drivers and older drivers, prefer a high boost ratio because it makes it easier for them to stop quickly without applying a large amount of pedal force that requires pressing one's back against the seat back, which they can't do. The boost ratio of the iBooster can be customized by software changes, which adjust how rapidly the current to the electric motor changes with changes in the pedal force

Hysteresis is the change in pedal force needed to get the same brake pressure to the pads for an increasing transfer function and a decreasing transfer function. Hysteresis is felt by the driver as a slight increase in the pedal pressure as he releases the brake pedal, which is an annoying feeling that suggests the brakes are grabbing or defective. The hysteresis should be as low as possible for good brake operation. The iBooster minimizes hysteresis by using slightly different amounts of electric motor torque for the increasing and decreasing transfer curves, with the amounts being software programmable.

Runout pressure is the TMC brake pressure at which brake boost ceases, leaving only the unboosted transfer of brake pedal force to the brake pads. Above the runout pressure the slope of the transfer curve becomes equal to the slope without any boost, which means that the driver must supply a much higher brake pedal force to stop the vehicle. Heavier vehicles require higher values of runout pressure, so runout pressure must be tailored to the vehicle weight. The runout pressure is determined by the maximum torque that the booster motor can supply. This maximum torque is determined either by the maximum current to the motor or the maximum torque that the motor is designed for at some maximum current. In the first case, it is possible to increase the motor torque by software adjustment of the motor current. In the latter case, a more powerful electric motor can be substituted to get a higher torque. Bosch can supply the iBooster with four different electric motors to provide different amounts of torque to meet the needs of different vehicle weights.

Knowing how these iBooster parameters can be changed by software to change the pedal feel, one might wonder how Tesla was able to revise their braking system so quickly in just a two weeks to pass new braking tests by slashing 20 feet from the stopping distance after their Model 3 failed *Consumer Reports* tests with a braking distance of 152 feet from 60 mph<sup>53, 54</sup>. It would appear that the changes they made affected the boost magnitude. Although a change in boost ratio could affect how quickly the boost is applied, the test involves jamming on the brakes in an emergency braking maneuver, so the time it takes for the boost to increase is so small that differences in boost rate are minimal. Also, a change in the brake force distribution curve was probably not made because regen is not a factor at such high braking decelerations and the brake distribution curve should have already been optimized for proper front wheel braking. Instead, they likely changed the runout pressure, i.e., the maximum boost, by either increasing the current to the electric boost motor, or more likely, by changing the boost motor itself to one having a higher torque output. This would mean that their initial brake system was under-designed for the weight of the vehicle (Tesla vehicles are heavier than many ICE vehicles

because of the weight of the battery) and that a higher runout pressure, or higher boost value, was needed to give a higher braking force for the higher weight involved. This could have been done easily with a two-week turnaround, and would have been an acceptable solution as long as all future production vehicles use the same electric boost motor and electric current values as the iBooster used in the tests.

## Appendix 2. Recalls on Brake Switch Failures

Over the past twenty years, nearly every vehicle manufacturer has had a problem with faulty brake light switches. Hundreds of thousands of vehicles have been recalled to replace these faulty brake light switches. In nearly every case, the faulty switches have caused the brake lights to fail to turn on when the brake pedal was pressed. The following are some of the cases that have been reported.

1. Hyundai. In 2011, Hyundai announced a recall of 227,000 Hyundai vehicles for faulty brake light switches. The recall covered eight models from August 2002 to August 2011. The brakes would still work and the brake lights would still work, but the faulty switches could cause a delay of up to two seconds in the brake lights turning on.<sup>55</sup>

In 2011, Hyundai announced a second recall of 99,500 2009-2011 Hyundai Accents for a malfunctioning brake light switch that could cause the brake lights to not illuminate when the brake pedal is depressed or could cause an inability to deactivate the cruise control by depressing the brake pedal.<sup>56</sup>

2. Subaru. On March 2, 2019, Subaru announced a recall of 1,303,530 Subaru vehicles for faulty brake light switches. The recall stated: “When exposed to certain contaminants, the brake light switch may malfunction, preventing the brake lights from illuminating”. According to a [National Highway Traffic Safety Administration Safety Recall Report](#) on this issue, silicone gas may seep into the brake lamp switch housing. If this happens when closure of the contacts occurs, silicon dioxide may form a deposit layer on the switch contact terminal. The contact switch may fail to operate once this compound buildup reaches a certain level.<sup>57</sup>

In the recall notice with Japanese regulators, Subaru said that certain chemical compounds from everyday products, including fabric softener, cosmetics or even nail polish could cause an insulating layer of film on the switches that could interfere with the lights being able to turn on properly and also prevent the engine from turning on.<sup>58</sup>

3. Kia. In 2013, Kia announced a recall of 8000 vehicles between 2008 and 2011 to fix a brake light switch that might malfunction, meaning brake lamps could fail to operate or the cruise control might not deactivate when the brake pedal is depressed. In Safety alert A12/0592/13, Kia stated: “A fault in the brake light switch may result in the brake light not coming on when the brake pedal is pressed, or in the brake light remaining on. Moreover, in vehicles with automatic transmission it may not be possible to move the lever out of the ‘P’ position. The electronic stability control (ESC) may fail to operate, causing the ‘ESC OFF’ warning lamp on the dashboard to light up.”<sup>59</sup>
4. Suzuki. In 2019 Suzuki announced a recall for a stop lamp switch can fail in a manner that results in failure of the stop lamp to illuminate when only the rear brake is used. ... In October and November 2018, SMC conducted an in-depth investigation of how the structure of the stop lamp switch might contribute to the reported problems. Suzuki found that, for the stop lamp switch produced by the Chinese supplier, the part of the switch that moves against the switch body when the stop lamp is activated and deactivated can become more worn than the corresponding part in the switch produced by the Japanese supplier (the contact part of the switch produced by the Japanese supplier is coated with grease and the contact part of the switch produced by the Chinese supplier is not). .. In December 2018 to April 2019, Suzuki continued to conduct reproduction testing. With repeated switch operation in a corrosive environment, Suzuki was able to reproduce failure of the stop lamp switch.<sup>60</sup>

5. Toyota. In 2013 Toyota issued a recall of 70,500 2009 Camry's and 116,00 2009 Venza's because of faulty stop lamp switches. The recall stated: "During installation of the contact-type stop lamp switch into the vehicle, silicon grease may have reached the inside of the switch, and could cause an increase in electrical resistance. If this occurs, warning lamps could be illuminated, the vehicle may not start, or the shift lever may not shift from the "Park" position. In some cases, the vehicle stop lamps could become inoperative."<sup>61</sup>
6. General Motors. In 2009, GM issued a recall of 2005-2007 Pontiac G6 vehicles for a highly elevated incident rate of improper operation of the brake lamps. Recall number 09V036000, dated January 30, 2009, stated: "Consumers could use their brakes and discover that the brake lamps would not illuminate when the brake pedal is applied, or the brake lamps would illuminate when the brake pedal was not applied. Primary cause of this brake condition was fretting corrosion (oxidation) of the connector pins on the body control module (BCM) that connect to the brake pedal position sensor (BPPS). The corrosion prevents the BCM from receiving the correct signal voltage from the BPPS."
7. General Motors. In 2014, GM issued a second recall of 2,440,524 vehicles with electrical problems in the Body Control Module (BCM). The problems could cause the brake lights to turn on when not pressing the brake pedal or not turn on when the brake pedal is applied. GM Technical Service Bulletin 13036A – Brake Lamp Malfunction stated: "General Motors has decided that a defect which relates to motor vehicle safety exists in the following vehicles:
  - a. 2004-2012 model year (MY) Chevrolet Malibu,
  - b. 2004-2007 MY Chevrolet Malibu Maxx,
  - c. 2005-2010 MY Pontiac G6,
  - d. 2007-2010 MY Saturn Aura.

On these vehicles, over time an increased resistance can develop in the Body Control Module (BCM) connection system and result in voltage fluctuations or intermittency in the Brake Apply Sensor (BAS) circuit that can cause service brake lamp malfunction. As a result, the service brake lamps may illuminate when the service brakes are not being applied, or may not illuminate when the service brakes are being applied." ... "In the affected vehicles, increased resistance in the Body Control Module (BCM) connection may result in voltage fluctuations in the Brake Apply Sensor (BAS) circuit. These fluctuations can cause one or more of these conditions:

- a) the brake lights to illuminate without the brake pedal being pushed;
  - b) the brake lights to not illuminate when the pedal is pushed;
  - c) difficulty disengaging the cruise control;
  - d) moving the gear shifter out of the 'PARK' position without pushing the brake; and disablement of crash avoidance features such as traction control, electronic stability control, and
  - e) panic braking assist features"<sup>62, 63</sup>
8. General Motors. GM may also have a problem with the actual brake light switch. Here is a discussion found on the internet about a Chevy Tahoe Suburban:

#### CobraEatr

When I press the brake pedal, the brake lights will come on, but there is about a 2 to 3 second delay before they come on. ... The brake lights do work (all of them), but there is a delay when I press the brake pedal to put the car in gear. The delay is about two seconds or so. ... Problem solved. ... I changed the brake light switch (P/N 15128592 - for adjustable power pedals, \$25 at the Chevy dealership) and everything is now working perfectly. ... It was just the switch that went out and was making things work sometimes, but with a delay.

I opened up the old switch and there were some burnt looking metal strips in it. So it fried at some point.

[SASIRMON87](#)

The brake light switch has two spring-loaded contacts inside that complete the circuit and they will get kinda burned sometimes and don't make good contact.<sup>64</sup>

9. [Ford](#). On November 10, 2014, Ford announced a recall of 950 2014 F-150's for an issue with the brake pedal position switch. If this switch is incorrectly adjusted it could result in a delay in the brake lights lighting up or not lighting up at all when the brake pedal is depressed.<sup>65</sup>

This recall, however, did not cover the following discussion on the Ford F150 Forum about a Ford F10 truck and a 91 Ford F150:

[mr7confused](#)

I've noticed that my brake lights activate significantly later than my pedal starts affecting the stopping. I can stop at a light, and keep the truck stopped with the brake lights off.

[mrleno](#)

I have a 91 [F150 XLT](#) Lariat 2WD with the same problem.<sup>66</sup>

10. [BMW](#). The following posting by a member named "c2d" was found on the Bimmer Forum:

C2d

"I just noticed tonight my brake lights are coming on a full 4 or 5 seconds after I apply the brake...as long as I keep my foot on the brake. ... New brake light switch fixed it!<sup>67</sup>

11. [Tesla](#). The following posting by a member named "Joelgir" was found on the Tesla Motors Club Forum on July 13, 2018:

Joelgir,

When backing into my garage, my brake lights weren't coming on either in the back of the car or on the dash. I did some testing and found out that the brake lights came on during regen, would turn off during mechanical braking, and then would turn back on when the brake hold activated, leaving me exposed with no brake lights whenever I was braking with the brake pedal. ... Brought it into Tesla service and they were able to reproduce it. However the part they needed, a replacement brake pedal switch, had to be ordered so I left with the car.<sup>68</sup>

### **Appendix 3. Tesla Sudden Acceleration Incidents**

The Tesla sudden acceleration incidents in this appendix were extracted from a legal brief for a Class Action Suit on Tesla Sudden Acceleration filed in a California court entitled Lee v. Tesla Inc, dated Jan 20, 2020.<sup>69</sup> All incidents have been reported to NHTSA.

The incidents have been divided into three categories:

- D. Incidents starting while slowing down with turning to park or while accelerating with turning to leave a parking position (70 incidents),
- E. Incidents starting from a stationary position (27 incidents), and
- F. Incidents starting at high speed (5 incidents).

The descriptions omit all information about dates, locations, injuries, vehicle damage, and follow-on communication with dealers and Tesla, leaving only information about the incidents themselves. This was done to save the reader's time, and to help the reader to see similarities between the incidents.

#### **A. Incidents starting while slowing down with turning to park or while accelerating with turning to leave a parking position**

1. March 30, 2018 **NHTSA ID NUMBER: 11082114**

I WAS DRIVING AT 10 MPH, PULLED INTO MY DRIVEWAY MADE 90 DEGREES TURN AT 5 MPH, APPLIED THE BRAKES. INSTEAD OF STOPPING, CAR SPED UP AT EXTREMELY HIGH ACCELERATION.

2. March 6, 2017 **NHTSA ID NUMBER: 10958834**

WAS PARKING OUR TESLA MODEL S P85+ AND SLOWLY MOVING INTO THE PARKING SPOT NEARING THE FINAL DISTANCE IN TO THE SPOT, WHEN THE CAR SUDDENLY LURCHED FORWARD...

3. September 26, 2013 **NHTSA ID NUMBER: 10545488**

WAITING TO TURN LEFT INTO THE PARKING GARAGE. WHEN IT WAS CLEAR OF ONCOMING TRAFFIC FOR ME TO MAKE THE LEFT TURN, I RELEASED MY FOOT OFF THE BRAKE PEDAL AND THE CAR INSTANTLY SURGED FORWARD VERY FAST.

4. September 24, 2013 **NHTSA ID NUMBER: 10545230**

THE CAR WAS GOING AT ABOUT 5 MPH GOING DOWN A SHORT RESIDENTIAL DRIVEWAY. BRAKE WAS CONSTANTLY APPLIED. THE CAR SUDDENLY ACCELERATED. ... ENGINEER FROM TESLA SAID THE RECORD SHOWED THE ACCELERATING PEDAL WAS STEPPED ON AND IT ACCELERATED FROM 18% TO 100% IN A SPLIT SECOND. ... HE ALSO SAID THERE WAS A BUILT-IN SAFE-GUARD THAT THE ACCELERATOR COULD NOT GO BEYOND 92%. THE STATEMENTS ARE CONTRADICTORY.

5. December 14, 2019 **NHTSA ID NUMBER: 11289019**

WAS SLOWLY APPROACHING OUR GARAGE DOOR WAITING FOR THE GARAGE DOOR TO OPEN WHEN THE CAR SUDDENLY LURCHED FORWARD. ... TWO MARKS ON THE GARAGE FLOOR INDICATE THE REAR DRIVE WHEELS CONTINUED TO SPIN EVEN AFTER HITTING THE CONCRETE WALL.

6. August 24, 2015 **NHTSA ID NUMBER: 10758908**

I PULLED INTO A PARKING SPACE MAKING A LEFT TURN INTO THE SPOT. AS I PULLED IN, I LET MY FOOT OFF OF THE ACCELERATOR, AND APPLIED THE BRAKE. THE CAR LURCHED FORWARD.

7. February 15, 2016 **NHTSA ID NUMBER: 10836289**

CAR WAS GOING VERY SLOW AS THE DRIVER WAS TURNING TO EXIT THE COMPOUND THROUGH A GATED ENTRANCE. THE CAR SUDDENLY ACCELERATED. ... ELECTRONIC RECORDS ACCESSED ON SEPTEMBER 15, 2015 REVEALED THE FOLLOWING INFORMATION: THE CAR WAS ORIGINALLY BEING DRIVEN AT 4.7 KM/HR WITH THE ACCELERATION PEDAL DEPRESSED AT 2.8%. WITHIN ONE SECOND, THE ACCELERATION PEDAL WENT FROM BEING DEPRESSED 2.8% TO 84.8% AND THE CAR INCREASED TO 10.75 KM/HR. DURING THE FOLLOWING SECOND, THE CAR'S RECORDS SHOW THE ACCELERATOR PEDAL TO CONTINUE TO BE COMPRESSED AT 84% WITH THE SPEED INCREASING TO 18.35 KM/HR, **BUT WITH THE BRAKE PEDAL ALSO BEING SIMULTANEOUSLY COMPRESSED**. IN THE SUBSEQUENT SECOND, THE ANTI-LOCK BRAKES INITIATED, AND THE CAR WAS BROUGHT TO A STOP A SECOND LATER. WE REJECT THE DEALERSHIP'S DECISION THAT THIS WAS DRIVER'S ERROR. IN SUCH A NARROW ENVIRONMENT AS THE HOUSING COMPOUND, AND DURING A SLOW AND CONTROLLED TURN,

8. September 29, 2014 **NHTSA ID NUMBER: 10639849**

WHILE PULLING INTO A PARKING SPACE, THE VEHICLE SURGED FORWARD, JUMPED THE CURB.

9. September 29, 2014 **NHTSA ID NUMBER: 10639935**

I PULLED SLOWLY IN TO A PARKING SPOT & MY CAR WAS AT A STOP POSITION JUST READY TO PUSH PARK BUTTON. WITHIN A SPLIT OF A SECOND, MY CAR (TESLA) JUMPED THE CURB. THIS IS THE LOG FILE DATA WORD BY WORD FROM THEM. "AT THE TIME OF THE INCIDENT THAT RESULTED IN DAMAGE TO YOUR VEHICLE, YOU INCREASED THE ACCELERATOR PEDAL POSITION FROM 1% TO 50% IN LESS THAN ONE SECOND WITHOUT DEPRESSING THE BRAKE PEDAL. ONE SECOND LATER, YOU INCREASED THE ACCELERATOR PEDAL TO 100% WITHOUT DEPRESSING THE BRAKE PEDAL. ONE SECOND LATER, YOU CONTINUED DEPRESSING THE ACCELERATOR PEDAL AT 100% WITHOUT DEPRESSING THE PEDAL; HOWEVER, THE VEHICLE'S TRACTION CONTROL ENGAGED & THEREFORE LIMITED THE VEHICLE'S TORQUE DESPITE THE FACT YOU WERE DEPRESSING THE ACCELERATOR PEDAL AT 100% UNTIL YOU DEPRESSED THE BRAKE PEDAL IN THE FOLLOWING SECOND".

10. January 8, 2020 **NHTSA ID NUMBER: 11297839**

AS I DROVE MY 2015 TESLA MODEL S FORWARD AND STEERED TO THE RIGHT INTO A PARKING SPOT, I CONSCIOUSLY EASED MY RIGHT FOOT OFF FROM THE ACCELERATOR PEDAL, THUS LOWERING MY SPEED FROM 10-9 MPH TO ABOUT 5-6 MPH. THE BRAKE PEDAL WAS NOT PRESSED, ALLOWING REGENERATIVE BRAKING TO SLOW DOWN THE VEHICLE. ABOUT A SECOND INTO THE PARKING TURN, THE VEHICLE SUDDENLY JOLTED FORWARD, ACCELERATING UNEXPECTEDLY. .... I FELT AS IF THE BRAKES FAILED TO

WORK. ... I CAUGHT MYSELF STILL FLOORING THE BRAKE PEDAL WITH MY RIGHT FOOT, AND CONTINUED TO FLOOR IT UNTIL I AFTER I HAD SHIFTED IT INTO PARKING GEAR.

11. March 11, 2018 **NHTSA ID NUMBER: 11078571**

WHILE PULLING INTO A PERPENDICULAR PARKING SPOT IN A PARKING GARAGE, AT ~4-5 FEET FROM A WALL, THE CAR EXPERIENCED SUDDEN ACCELERATION. ... THEY HAVE TOLD ME THAT THE CAR SPEED WAS 3.6 MPH AT WHICH TIME THE DATA INDICATES THAT THE ACCELERATOR WAS PRESSED TO AS FAR AS 100%, RESULTING IN ACCELERATION OF THE CAR TO 7 MPH AT THE TIME OF IMPACT, WITH THIS ACCELERATION OCCURRING OVER A 2 SECOND TIME PERIOD. THIS INFORMATION SEEMS INCOMPATIBLE WITH THE OTHERWISE RAPID ACCELERATION TYPICALLY EXHIBITED BY THIS CAR WITH A FULLY DEPRESSED ACCELERATOR, AND THE SHORT DISTANCE TRAVELED (ONLY SEVERAL FEET).

12. March 24, 2017 **NHTSA ID NUMBER: 10968322**

AS I APPROACHED MY PARKING SPOT, I SLOWED MY CAR BY PRESSING ON THE BRAKE AND MADE A 90 DEGREE TURN INTO MY PARKING SPOT. THE VEHICLE WAS SLOWING MOVING FORWARD AND WAS LESS THAN 10 FEET FROM WHERE I INTENDED TO STOP THE VEHICLE, WHEN THE VEHICLE SUDDENLY ACCELERATED ON ITS OWN AND CRASHED INTO THE CONCRETE WALL. ... I DID NOT HAVE MY FOOT ON THE ACCELERATOR PEDAL AT THE TIME THE VEHICLE ACCELERATED INTO THE WALL.

13. September 27, 2016 **NHTSA ID NUMBER: 10910065**

I DROVE THE CAR INTO A PARKING SPACE. ... WHEN THE CAR ACCELERATED ON ITS OWN (UNINTENDED ACCELERATION).

14. June 17, 2016 **NHTSA ID NUMBER: 10874744**

CAR RAPIDLY ACCELERATED TO MAXIMUM THROTTLE DURING PARKING MANEUVER IN A PARKING STRUCTURE. I WAS TRAVELLING AT 3MPH. CAR ACCELERATED.

15. May 11, 2016 **NHTSA ID NUMBER: 10864353**

MY WIFE WENT TO PULL INTO A PARKING SPOT, SHE TOOK HER FOOT OFF THE ACCELERATOR PEDAL AND THE CAR ACCELERATED "FULLY".

16. December 15, 2015 **NHTSA ID NUMBER: 10810457**

ON THE AFTERNOON OF NOVEMBER 25, 2015, I WAS DRIVING INTO A STRIP MALL PARKING LOT. I WAS GOING TO PULL INTO ONE OF THOSE SPACES WHERE YOU CAN PARK PERPENDICULAR TO A SIDEWALK CURB. ... WHEN APPROACHING THE PARKING SPACE, THE CAR WAS ALREADY IN REGENERATIVE BRAKING MODE, AND ACCORDING TO TESLA'S LOGS, THE CAR SLOWED DOWN TO 3.5 MPH. SINCE THE CAR HAD ENOUGH MOMENTUM TO ROLL INTO THE SPACE ON ITS OWN, MY FOOT WAS NOT ON THE ACCELERATOR OR THE BRAKE PEDAL. MY FOOT WAS UP RESTING ON ITS HEEL, READY TO TAP THE BRAKE WHEN IT GOT CLOSE ENOUGH TO THE CURB. **WHILE THE CAR WAS COASTING INTO THE SPACE THE MOTOR WAS VERY QUIET. ALL OF A SUDDEN, I HEARD A "WHIRRING" SOUND FROM THE MOTOR.** I DON'T KNOW HOW BETTER TO DESCRIBE IT,

THAN TO SAY IT WAS ALMOST LIKE THE MOTOR WENT FROM A STATE OF SLUMBER TO A FULL STATE OF AWARENESS. I BELIEVE THE MOTOR WAS “WHIRRING” LOUDLY FOR ABOUT A SECOND BEFORE THE CAR TOOK OFF AT SUCH A FAST PACE AND WOUND UP HITTING A BRICK WALL. ... ACCORDING TO TESLA’S LOGS, THE DATA READS THAT THE PEDAL WAS DEPRESSED DOWN TO 97% AND THE CAUSE OF THE ACCIDENT WAS DUE TO DRIVER ERROR. I STAND FIRMLY BY MY STATEMENT THAT MY FOOT WAS NOT ON EITHER THE ACCELERATOR OR THE BRAKE PEDAL WHEN THE CAR ACCELERATED. DATA MAY SHOW THERE WAS PEDAL DEPRESSION BUT I DID NOT DO THE DEPRESSING. THIS WAS DUE TO UNINTENDED ACCELERATION BY THE CAR.

17. April 29, 2016 **NHTSA ID NUMBER: 10862194**

THE CAR WAS BEING SLOWLY PULLED INTO A PARKING SPACE AT A BANK WHEN IT EXPECTANTLY ACCELERATED. IT JUMPED A CURB, ... HE CAR WAS BEING SLOWLY PULLED INTO A PARKING SPACE AT A BANK WHEN IT EXPECTANTLY ACCELERATED. IT JUMPED A CURB.

18. November 19, 2019 **NHTSA ID NUMBER: 11280962**

MY WIFE WAS PULLING INTO A PARKING SPOT AT HER SCHOOL AT A SLOW RATE OF SPEED (AS SHE WAS PARKING BETWEEN 2 CARS). ... WHEN SHE WAS ROUGHLY  $\frac{3}{4}$  OF THE WAY INTO THE PARKING SPOT WITH HER FOOT ON THE BRAKE, THE VEHICLE ACCELERATED ON ITS OWN AS IF IT WAS IN PERFORMANCE MODE.

19. March 15, 2018 **NHTSA ID NUMBER: 11079500**

I WAS ATTEMPTING TO PARK IN FRONT OF A RETAIL BUSINESS WHEN THE CAR SUDDENLY AND UNEXPECTEDLY ACCELERATED. ... THE SUDDEN AND UNEXPECTED ACCELERATION HAPPENED WITH NO INPUT TO THE ACCELERATOR PEDA. I WAS LIGHTLY BRAKING, INTENT ON COMING TO A COMPLETE STOP. I HAD NEARLY COMPLETED THE PARKING MANEUVER WHEN THE CAR RACED FORWARD,

20. January 31, 2018 **NHTSA ID NUMBER: 11066047**

AS MY HUSBAND WAS PULLING INTO A PARKING SPACE AND COMING TO A STOP, THE CAR SUDDENLY ACCELERATED AT HIGH SPEED, WENT OVER THE CEMENT BUMPER FOR THE SPACE. ... WE TOOK THE CAR IN TO TESLA WHO RAN A DIAGNOSTIC. THEY ADVISED THAT THE THROTTLE WENT SUDDENLY FROM 2% TO 97% AND THEN THE BRAKE WAS APPLIED, BUT WHEN I ASKED FOR MORE DETAILS ABOUT THE APPROACH TO THE PARKING SPACE, FOR A COPY OF THE REPORT THEY SAID THEY WOULD NOT PROVIDE IT WITHOUT A SUBPOENA.

21. December 15, 2017 **NHTSA ID NUMBER: 11054973**

WHILE ATTEMPTING TO PARK MY TESLA S75 D IN A COSTCO SPACE, THE CAR BOLTED.

22. November 1, 2017 **NHTSA ID NUMBER: 11042211**

WHILE PARKING, THE VEHICLE INADVERTENTLY ACCELERATED. ... THE BRAKE PEDAL WAS DEPRESSED, BUT THE VEHICLE FAILED TO STOP. ... THE FAILURE OCCURRED A SECOND TIME WHILE PARKING IN A HOSPITAL PARKING LOT. THE VEHICLE

ACCELERATED WITHOUT WARNING, JUMPED A CURB, AND COLLIDED WITH A METAL POLE.

23. February 9, 2017 **NHTSA ID NUMBER: 10953656**

SHE PULLED INTO HER DRIVEWAY AT HOME AND BROUGHT THE VEHICLE TO A STOP. WITH HER FOOT STILL ON THE BRAKE, THE VEHICLE SUDDENLY ACCELERATED ON ITS OWN FROM A STOPPED POSITION TO SPEEDS OF BETWEEN 40-60 MPH.

24. April 4, 2018 **NHTSA ID NUMBER: 11083342**

WHEN I PULLED INTO THE DRIVEWAY THE SELF DRIVING FEATURES ACCELERATED THE VEHICLE CAUSING AN ACCIDENT.

25. June 16, 2017 **NHTSA ID NUMBER: 10995447**

VEHICLE ACCELERATED SUDDENLY AND CRASHED INTO A TREE IN FRONT WHILE PARKING THE CAR IN A PARKING LOT.

26. February 27, 2017 **NHTSA ID NUMBER: 10957394**

WHEN I WAS ABOUT TO PARK THE CAR IN THE PARKING LOT (AROUND 6 MILES PER HOUR MAY BE) IT SUDDENLY ACCELERATED.

27. January 3, 2017 **NHTSA ID NUMBER: 10939234**

WHILE TURNING LEFT INTO A PARKING SPOT AT A VERY SLOW SPEED, THE CAR SUDDENLY ACCELERATED WITH EXTREME FORCE. IT RAN OVER A CURB AND COLLIDED WITH A TREE AND A TRUCK.

28. December 14, 2016 **NHTSA ID NUMBER: 10935272**

I HAD PULLED INTO A PARKING LOT, PROCEEDED TO PULL INTO A SPOT ADJACENT TO A CINDER BLOCK BUILDING. I HAD MY FOOT LIGHTLY ON THE GAS PEDAL, THEN AS I MADE THE TURN INTO THE SPOT, MY FOOT WAS ON THE BRAKE - THE CAR LURCHED FORWARD AND SPED UP AND THE BRAKES DID NOT STOP IT.

29. October 12, 2016 **NHTSA ID NUMBER: 10915633**

WHILE PARKING THE VEHICLE, IT ACCELERATED WHILE DEPRESSING THE BRAKE PEDAL.

30. September 26, 2016 **NHTSA ID NUMBER: 10909588**

I WAS GOING UP BY DRIVEWAY WAITING FOR MY GARAGE DOOR TO OPEN. I TOOK MY FOOT OFF THE ACCELERATOR AND WAS SLOWING DOWN WITHOUT HITTING THE BRAKES WAITING FOR THE GARAGE DOOR TO OPEN. THE CAR TOOK OFF THROUGH THE GARAGE DOOR AND HIT MY HUSBANDS CAR SITTING IN THE GARAGE.

31. September 19, 2016 **NHTSA ID NUMBER: 10908051**

WHILE TURNING LEFT TO ENTER A VERY NARROW GARAGE ENTRANCE. ... I SAW THAT I WAS IN THE POSITION THAT I COULD CONTINUE INTO THE GARAGE AND LIGHTLY PRESSED THE ACCELERATOR TO FINISH MY TURN INTO THE GARAGE. IT WAS AT THIS

POINT THAT THE CAR ACCELERATED WITH EXTREME FORCE AND WITHIN A SECOND SLAMMED INTO A LARGE CONCRETE POLE THAT WAS JUST INSIDE THE GARAGE TO THE LEFT. ... I DID NOT HAVE EITHER FOOT DEPRESSED ON EITHER PEDAL. ... AT FIRST TESLA TOLD US OVER THE PHONE THAT THEIR LOGS SHOW THAT THE DRIVER PRESSED THE PEDAL 100% AND THEN TAPPED THE BRAKE BEFORE IMPACT. THIS EXPLANATION SOUNDED PHYSICALLY IMPOSSIBLE BECAUSE THE DISTANCE COVERED WAS LESS THAN 3 CAR LENGTHS. A MONTH LATER TESLA SENT A LETTER STATING THE DRIVER PRESSED THE ACCELERATOR 100% UNTIL THE VEHICLE SENSED A CRASH. TESLA DID NOT RESPOND TO OUR QUERY ABOUT WHY THEIR LOG STORY HAD CHANGED. TESLA ALSO REFUSED TO PROVIDE DATA ABOUT ACCELERATOR/BRAKE PERCENTAGE AND CAR SPEED.

32. August 24, 2016 **NHTSA ID NUMBER: 10898260**

WHILE SLOWLY PULLING INTO A PARKING SPACE... MY TESLA MODEL X SUDDENLY ACCELERATED UNDER ITS OWN VOLITION. ... AT TESLA OF TAMPA, TOLD ME VERBALLY THE LOG FROM THE EDR SAYS THE CAR WAS TRAVELING AT 6 MPH, THEN THE ACCELERATOR WAS ADVANCED TO OVER 50% AND THEN TO 87%. THE CAR ACCELERATED TO 20 MPH AND ABRUPTLY STOPPED. I DENIED THIS SCENARIO AND ASKED FOR A SUPERVISOR. TESLA'S SOUTHEAST REGIONAL MANAGER MET US AT THE BODY SHOP. HE HANDED ME A LETTER THAT HAD DIFFERENT EDR RESULTS-VEHICLE SPEED WAS 7 MPH, PEDAL POSITION WENT FROM 3.2% TO 15.6% TO 100% AND CAR WENT TO 14 MPH.

33. August 4, 2016 **NHTSA ID NUMBER: 10893066**

WHILE ATTEMPTING TO PARK, THE VEHICLE INDEPENDENTLY ACCELERATED.

34. June 7, 2016 **NHTSA ID NUMBER: 10873117**

WHILE ENTERING A PARKING STALL SUDDENLY AND UNEXPECTEDLY ACCELERATED AT HIGH SPEED ON ITS OWN.

35. July 3, 2019 **NHTSA ID NUMBER: 11229124**

WHILE ATTEMPTING TO PARK THE CAR IN A PARKING SPACE THE CAR ACCELERATED ON ITS OWN.

36. March 18, 2019 **NHTSA ID NUMBER: 11189710**

WHILE PULLING IN THE DRIVEWAY AT APPROXIMATELY 5 MPH, THE CONTACT ATTEMPTED TO STEP ON THE BRAKE PEDAL TO SLOW DOWN THE VEHICLE. HOWEVER, THE VEHICLE ACCELERATED THROUGH THE GARAGE.

37. December 21, 2018 **NHTSA ID NUMBER: 11162968**

OUR TESLA HAS HAD TWO INCIDENTS IN THE LAST THREE MONTHS OF UNCONTROLLABLE ACCELERATION....ONCE SLOWLY GOING INTO A PARKING PLACE AND ONCE BACKING OUT OF OUR GARAGE.

38. July 25, 2018 **NHTSA ID NUMBER: 11113560**

WHILE DRIVING 5 MPH, THE VEHICLE ACCELERATED RAPIDLY WITHOUT WARNING.

39. May 29, 2018 **NHTSA ID NUMBER: 11098517**

WHILE ATTEMPTING TO PARK THE VEHICLE AT A LOW SPEED, THE VEHICLE SUDDENLY ACCELERATED WITH THE BRAKE PEDAL DEPRESSED.

40. January 24, 2018 **NHTSA ID NUMBER: 11064628**

I WAS PULLING IN TO MY OFFICE PARKING SPOT. ... I LET THE CAR SLOW TO ROLL CLOSER IN FRONT OF THE CURB. ALL OF A SUDDEN THE CAR ACCELERATED. ... TESLA SAID I WAS ON THE PEDAL FOR A SECOND LONG, I APPLIED PEDAL FROM 0-18%, AND QUICKLY APPLIED THE BRAKE.

41. September 4, 2017 **NHTSA ID NUMBER: 11021371**

I WAS DRIVING DOWN THE DRIVEWAY SLOWLY AND THE CAR SUDDENLY ACCELERATED TO A VERY HIGH SPEED.

42. September 11, 2018 **NHTSA ID NUMBER: 11128789**

AS I WAS PULLING INTO THE PARKING SPACE THE TESLA RAPIDLY ACCELERATED.

43. April 7, 2018 **NHTSA ID NUMBER: 11083755**

MY CAR HAD AN UNINTENDED ACCELERATION WHEN I WAS TRYING TO PARK IN THE PARKING LOT OF MY OFFICE.

44. March 7, 2018 **NHTSA ID NUMBER: 11076619**

I WAS PARKING WHEN I FELT THE VEHICLE SUDDENLY ACCELERATE AND JUMP THE CURB, SMASHING THROUGH THE FRONT WINDOWS/DOOR OF A BUSINESS.

45. February 16, 2018 **NHTSA ID NUMBER: 11073274**

WHILE ATTEMPTING TO PARK THE VEHICLE AND APPLY THE BRAKES AT 5 MPH, THE VEHICLE PICKED UP SPEED. AS A RESULT OF THE FAILURE, THE VEHICLE CRASHED INTO A SCHOOL BUILDING.

46. June 21, 2018 **NHTSA ID NUMBER: 11102931**

I WAS SLOWLY MOVING INTO A PARKING SPACE IN FRONT OF A SUPERMARKET WHEN THE CAR SUDDENLY ACCELERATED.

47. July 1, 2019 **NHTSA ID NUMBER: 11228597**

I DROVE TO WORK ON MAY 2, 2019, AND WAS TRYING TO PARK IN MY ALLOTTED PARKING STALL ON THE 3RD LEVEL OF MY OFFICE PARKING GARAGE. MY PARKING STALL WAS ALONG THE OUTER EDGE OF THE GARAGE AND THE ONLY BARRIER TO THE OUTSIDE WAS A SET OF THREE (ABOUT ¾ " DIAMETER) CABLES STRUNG BETWEEN OUTSIDE COLUMNS OF THE GARAGE, BESIDES A THIN PERFORATED CORRUGATED METAL SHEET OUTSIDE THE CABLES, ACTING AS A RAIN STOP. I WAS TRYING TO SLOWLY TURN RIGHT FROM THE PARKING AISLE TO PARK BETWEEN TWO PICKUP TRUCKS ON EITHER SIDE OF MY STALL. WHEN I HAD TURNED PARTWAY INTO MY STALL, MY TESLA SUDDENLY ACCELERATED INTO MY PARKING STALL AT HIGH SPEED, HIT THE OUTSIDE CABLES, REBOUNDED BACKWARDS AND STOPPED ABOUT 10 FEET

FROM THE OUTSIDE CABLES. THE CABLES SAVED ME FROM PLUNGING 3 FLOORS DOWN FROM THE GARAGE.

48. May 23, 2019 **NHTSA ID NUMBER: 11209483**

THE CAR UNINTENDED ACCELERATED WHEN I PULLED INTO GARAGE AND WAIT FOR GARAGE DOOR OPEN.

49. March 1, 2019 **NHTSA ID NUMBER: 11183545**

WHILE ATTEMPTING TO MAKE A LEFT TURN FROM A PARKING SPACE, THE VEHICLE ACCELERATED BACKWARDS IN A TIGHT CIRCLE.

50. June 6, 2018 **NHTSA ID NUMBER: 11100216**

WHILE ATTEMPTING TO PARK THE VEHICLE, IT INDEPENDENTLY ACCELERATED.

51. November 27, 2018 **NHTSA ID NUMBER: 11154380**

I WAS DRIVING MY TESLA X SLOWLY WITH AUTO PILOT OFF AND AUTO STEER OFF ON A SURFACE STREET. I WAS TRYING TO DO A U TURN. I VERIFIED THAT THERE WAS NO TRAFFIC, THAT THERE WAS AN AREA WHERE CARS WERE NOT PARKED ON THE LEFT SIDE OF THE STREET AND COULD USE A PARKING DRIVEWAY ON THE RIGHT THAT WILL ALLOW MORE SPACE TO PERFORM THE U TURN. I GENTLY PRESSED THE BRAKE TO FURTHER SLOWDOWN AND THEN VEERED A LITTLE TO THE RIGHT INTO THE DRIVEWAY AT LESS THAN 5 MPH. I STARTED TO TURN TO THE LEFT WHILE STILL GENTLY PRESSING THE BRAKE. AS SOON AS THE FRONT RIGHT WHEEL LEFT THE DRIVEWAY AND BEFORE I HAD COMPLETED THE U TURN, THE TESLA ALL OF A SUDDEN, ON ITS OWN SPONTANEOUSLY ACCELERATED TO FULL POWER (A TESLA X CAN GO FROM 0-60 MILES IN APPROX. 4 SECONDS). MY FOOT WAS STILL ON THE BRAKE, I DID NOT MOVE IT AND THEREFORE I DID NOT PRESS THE ACCELERATOR. THERE WERE NO OBJECTS OBSTRUCTING THE PEDALS. IN A SMALL FRACTION OF A SECOND, THE TESLA TRAVELED AT FULL SPEED TOWARDS THE TACOMA CAR PARKED AHEAD ON THE LEFT (LESS THAN 20 FEET AWAY).

52. October 23, 2018 **NHTSA ID NUMBER: 11142282**

WHILE IN A PARKING LOT AT LOW SPEED AND COMING AROUND A TURN TO PARK, TESLA SUDDENLY ACCELERATED FROM LOW SPEED TO HIGH SPEED.

53. July 15, 2018 **NHTSA ID NUMBER: 11111431**

WHEN SLOWLY PULLING INTO A PARKING SPOT, THE CAR ACCELERATED ON ITS OWN JUMPING THE CURB. ... THIS IS THE SECOND INCIDENT OF THE CAR ACCELERATING ON ITS OWN. THE FIRST TIME THIS OCCURRED ... I WAS SLOWLY DRIVING AROUND A TRAFFIC CIRCLE IN A RESIDENTIAL AREA AND THE CAR TOOK OFF ON ITS OWN.

54. May 8, 2018 **NHTSA ID NUMBER: 11092528**

WHILE PULLING INTO A PARKING SPACE, THE BRAKE PEDAL WAS DEPRESSED BUT THE VEHICLE INADVERTENTLY ACCELERATED OVER A CURB.

55. March 1, 2019 **NHTSA ID NUMBER: 11183334**

WAS PARKING IN MY DRIVEWAY. THE VEHICLE SUDDENLY ACCELERATED, HIT THE CLOSED GARAGE DOOR.

**56. NHTSA ID Number:** 11133222

TO PULL FORWARD OUT OF A PARKING SPACE (I BACKED IN), I GENTLY APPLIED THE ACCELERATOR PEDAL TO EASE FORWARD (AND TURN LEFT) OUT OF THE PARKING SPACE TO HEAD DOWN THE PARKING AISLE, THE CAR MOVED FORWARD MUCH FASTER THAN EXPECTED SO I LET OFF THE PEDAL. THE VEHICLE STOPS ACCELERATING AFTER LETTING OFF THE PEDAL. I TRY PRESSING THE PEDAL GENTLY AGAIN AND THE CAR LURCHES FORWARD PRETTY QUICKLY AS IF I DEPRESSED THE PEDAL ABOUT HALFWAY DOWN (I DID NOT). LETTING GO OF THE ACCELERATOR PEDAL DIDN'T SEEM TO KICK IN REGENERATIVE BRAKING SO I PRESSED ON THE BRAKE TO SLOW THE CAR DOWN TO A SPEED APPROPRIATE FOR A PARKING LOT .... IT'S ALMOST AS IF THE "THROTTLE MAP" WAS MESSED UP FOR A FEW SECONDS ASKING THE CAR TO DELIVER MUCH HIGHER CURRENT THAN IT SHOULD HAVE AT A 5-10% PEDAL POSITION.

**57. August 14, 2018 NHTSA ID NUMBER:** 11119991

I RELEASED THE ACCELERATOR PEDAL AND TURNED TO APPROACH THE CURB. WHEN THE VEHICLE WAS NEXT TO THE CURB, IT SUDDENLY ACCELERATED.

**58. May 22, 2018 NHTSA ID NUMBER:** 11097159

DRIVER FELT SUDDEN UNINTENDED ACCELERATION WHILE PARKING THE CAR. THE ACCELERATION HAPPENED WITHIN THE LAST COUPLE OF SECONDS WHEN THE CAR WAS TURNING 90° AT PRETTY NORMAL SPEEDS TO PARK.

**59. May 10, 2018 NHTSA ID NUMBER:** 11092830

WHILE ATTEMPTING TO PARK THE VEHICLE, THE BRAKE PEDAL WAS DEPRESSED, BUT THE WHILE ATTEMPTING TO PARK THE VEHICLE, THE BRAKE PEDAL WAS DEPRESSED,

**60. May 4, 2018 NHTSA ID NUMBER:** 11091970

WHILE TRYING TO PARK THE VEHICLE IN A PARKING LOT OF A GROCERY STORE. THE VEHICLE WAS IN THE PARKING SPACE POSITION WHEN IT SUDDENLY ACCELERATED WITHOUT ANY INPUT FROM THE DRIVER. THE BRAKES WERE APPLIED HOWEVER THEY FELT INOPERATIVE.

**61. October 14, 2019 NHTSA ID NUMBER:** 11268280

I WAS TRYING TO PARK MY VEHICLE IN A PARKING SPOT I WAS TRYING TO PARK MY VEHICLE IN A PARKING SPOT.

**62. May 22, 2019 NHTSA ID NUMBER:** 11209238

MY WIFE) DROVE UP MULTILAVEL PARKING LOT. ... SHE INITIALLY CHOSE A HEAD IN PARKING SPOT, THEN ATTEMPTED TO MOVE THE CAR FORWARD TO THE NEXT AISLE, SO THE CAR WOULD BE FACING FRONT WHEN SHE GOT OUT. THE CAR PICKED UP UNCONTROLLABLE AND EXTREMELY HIGH SPEED.

**63. April 16, 2019 NHTSA ID NUMBER:** 11196764

VEHICLE ENTERED A SHOPPING PLAZA AT SPEED UNDER 10MPH AND SUDDENLY ACCELERATED TO HIGH SPEED ON ITS OWN. THE BRAKES WOULD NOT WORK.

64. September 28, 2018 **NHTSA ID NUMBER: 11132177**

CAR WAS IN PARKING LOT (BOTH ON AUGUST 12 2018 AND ON SEPTEMBER 26 2018) AND COMING TO A STOP... MY FOOT WAS NOT ON THE ACCELERATOR BUT CAR JOLTED FORWARD.

65. September 2, 2018 **NHTSA ID NUMBER: 11124067**

I WAS PULLING INTO A DRIVEWAY WHEN MY FOUR WEEK OLD TESLA MODEL 3, UNEXPECTEDLY ACCELERATED.

66. October 21, 2019 **NHTSA ID NUMBER: 11269912**

WAS PULLING INTO THE DRIVEWAY AT 4 MPH, THE VEHICLE ACCELERATED AND CRASHED INTO THE GARAGE DOOR. ... THE STEERING WHEEL AND BRAKES SEIZED.

67. December 30, 2019 **NHTSA ID NUMBER: 11292014**

I AM SLOWLY DRIVING AT THE PARKING LOT. ... I AM SLOWLY PARKING MY CAR AND THEN THERE'S A SUDDEN UNINTENDED ACCELERATION ON MY CAR WHICH I CANNOT EVEN CONTROL OR STOP. THE ACCELERATION SPEEDS UP AUTOMATICALLY ON ITS OWN EVEN IF I'M STEPPING ON THE BRAKE.

68. July 15, 2019 **NHTSA ID NUMBER: 11231846**

MY TESLA MODEL 3 JUST SUDDENLY ACCELERATED AS I WAS TURNING RIGHT TRYING TO THE LOT TO PARK THE CAR.

69. November 4, 2019 **NHTSA ID NUMBER: 11278152**

I TURNED INTO A PERPENDICULAR PARKING SPACE IN A HOME DEPOT PARKING LOT. I LET UP ON THE ACCELERATOR AS THE CAR INCHED CLOSER TO THE CURB. AS I BEGAN TO PRESS THE BRAKE TO BRING THE CAR TO A COMPLETE STOP, THE CAR SUDDENLY LURCHED FORWARD.

70. January 14, 2020 **NHTSA ID NUMBER: 11299347**

WHILE PULLING INTO THE PARKING LOT OF A SHOPPING CENTER WITHOUT WARNING THE VEHICLE ACCELERATED.

## **B. Incidents starting from a stationary position**

1. March 26, 2018 **NHTSA ID NUMBER: 11081382**

WHILE STATIONARY WITH THE BRAKE PEDAL DEPRESSED, THE VEHICLE INDEPENDENTLY ACCELERATED RAPIDLY WITHOUT WARNING.

2. August 18, 2015 **NHTSA ID NUMBER: 10749575**

THE VEHICLE SUDDENLY ACCELERATED WITHOUT WARNING TO ITS MAXIMUM ACCELERATION RATE.

3. October 9, 2018 **NHTSA ID NUMBER: 11139174**

WHILE ATTEMPTING TO PARK THE VEHICLE IN THE DRIVEWAY, IT SPONTANEOUSLY ACCELERATED.

4. May 1, 2017 **NHTSA ID NUMBER: 10982961**

AS I WAS PARKING MY CAR I HEARD AND FELT THE CAR BEGIN TO ACCELERATE. I PUT THE CAR IN PARK AND STEP FIRMLY ON THE BRAKE PEDAL. THEN OF IT OWN VOLITION IT MOUNTED THE ADJOINING EMBANKMENT.

5. March 8, 2016 **NHTSA ID NUMBER: 10845619**

I WAS STOPPED AT A RED LIGHT AT AN INTERSECTION THE EVENING OF MARCH 2, 2016, WITHOUT ANY NOTICE, THE CAR ABRUPTLY ACCELERATED. MY FOOT WAS ONLY ON THE BRAKE.

6. December 27, 2019 **NHTSA ID NUMBER: 11291423**

2015 MODEL S 85D WAS REVERSED ONTO DRIVEWAY THEN PLACED IN PARK AND DOORS WERE CLOSED AND LOCKED. A FEW MOMENTS LATER THE VEHICLE STARTED ACCELERATING FORWARD TOWARDS THE STREET AND CRASHED INTO A PARKED CAR. FRONT WHEELS WERE RECEIVING POWER WHILE REAR WHEELS WERE LOCKED AND DRAGGING RATHER THAN WHEELS SPINNING. I REVERSED VEHICLE BACK ONTO DRIVEWAY AND IT HAPPENED ANOTHER 2 TIMES AFTER FIRST INCIDENT WITHIN A 30 MINTUE TIME SPAN.

7. January 20, 2019 **NHTSA ID NUMBER: 11171052**

I HAD PLACED THE CAR IN PARK AND WAS PREPARING TO EXIT THE VEHICLE WHEN IT SUDDENLY ACCELERATED AND HIT THE FRONT OF MY GARAGE WALL. THE CAR WAS IN PARK AND NOT MOVING. I HAD MY HAND ON THE DOOR HANDLE TO EXIT. I IMMEDIATELY SLAMMED THE BRAKES BUT THE CAR SEEMED TO KEEP GOING. IT JUST SUDDENLY ACCELERATED WHILE IN PARK.

8. April 19, 2017 **NHTSA ID NUMBER: 10979378**

WHEN STOPPED AT THE SIGNAL, THE VEHICLE ACCELERATED INDEPENDENTLY WITHOUT WARNING.

9. September 17, 2015 **NHTSA ID NUMBER: 10764853**

CAR WAS PARKED IN THE PARKING LOT. WHILE BACKING THE CAR, IT SPIN FAST OUT OF CONTROL EVEN THOUGH BACKING WAS STARTED AT A VERY SLOW SPEED.

10. August 8, 2018 **NHTSA ID NUMBER: 11118541**

WHILE IN REVERSE BACKING UP TO A CHARGE STATION IN A COVERED PARKING LOT, THE CAR WENT INTO SUDDEN ACCELERATION AND FAILED TO STOP.

11. June 9, 2018 **NHTSA ID NUMBER: 11100721**

I WAS DRIVING UP MY DRIVEWAY. UPON REACHING THE TOP OF THE DRIVEWAY, THE CAR SUDDENLY ACCELERATED BY ITSELF. ... I HAVE 4 PASSENGERS THAT CAN ATTEST TO THIS.

12. June 19, 2017 **NHTSA ID NUMBER: 11000077**

WHILE ATTEMPTING TO EXIT THE PARKED VEHICLE, IT INDEPENDENTLY ACCELERATED. ... WHEN THE BRAKES WERE APPLIED, THE VEHICLE CAME TO A STOP.

13. February 6, 2017 **NHTSA ID NUMBER: 10949955**

I WAS STOPPED AT A STOP LIGHT ... AS THE LIGHT TURNED GREEN, I SLOWLY PRESSED ON THE GAS TO MOVE FORWARD AND THE CAR TOOK OFF AT TOP SPEED. I HIT THE BRAKE BUT THE CAR DID NOT RESPOND – IT DID NOT SLOW DOWN OR STOP,

14. May 10, 2016 **NHTSA ID NUMBER: 10864163**

INCIDENT 1: MY WIFE WAS AT A STOP SIGN. SHE REMOVED HER FOOT FROM THE BRAKE AND BEFORE APPLYING THE ACCELERATOR THE CAR SURGED FORWARD AGGRESSIVELY. SINCE HER FOOT NEVER TOUCHED THE ACCELERATOR SHE WAS ABLE TO APPLY THE BRAKE AND STOP WITHIN 8-10 FEET. ... INCIDENT 2: ABOUT 2 WEEKS LATER, MAY 6, I WAS PULLING INTO MY GARAGE WITH MY WIFE AND BABY IN THE VEHICLE. 2-3 FEET FROM THE GARAGE WALL (IN CREEP MODE) I GENTLY TOUCHED THE BRAKE TO COME TO A STOP. AT THAT POINT THE CAR SURGED FORWARD VERY AGGRESSIVELY. I IMMEDIATELY APPLIED HEAVY BRAKE AND WAS ABLE TO STOP THE CAR IN A FEW FEET (SINCE MY FOOT WAS ALREADY OVER THE BRAKE PEDAL ... LOGS WERE DOWNLOADED AND SHOW THAT THE ACCELERATOR WAS DEPRESSED TO 97% POWER IN LESS THAN A SECOND AND THAT IT WAS DRIVER ERROR. ... MY WIFE IS 37, HEALTHY AND A PHYSICIAN, I AM A HEALTHY 42 YEAR OLD PILOT.

15. May 17, 2018 **NHTSA ID NUMBER: 11096621**

I NEEDED TO BACK INTO A SPOT TO BE ABLE TO TAKE PART IN THE FUNERAL PROCESSION. ... AT THE SAME MOMENT THAT I STARTED TO BACK IN, THE CAR SURGED AND MADE AN ARC IN THE PARKING LOT ONLY STOPPING AFTER I HIT A PARKED CAR. ... I WAS TOLD IT COULD BE THE AUTO PILOT SYSTEM THAT COULD BE A FAULT EVEN THOUGH I HAVE NEVER USED IT.

16. April 4, 2018 **NHTSA ID NUMBER: 11083342**

WHEN I PULLED INTO THE DRIVEWAY THE SELF DRIVING FEATURES ACCELERATED THE VEHICLE CAUSING AN ACCIDENT.

17. August 24, 2016 **NHTSA ID NUMBER: 10898260**

MY WIFE WAS WAITING IN LINE AT A CAR WASH. WHILE WAITING FOR THE CAR IN FRONT OF HER TO MOVE OUT OF THE CAR WASH TUNNEL, SHE HAD HER FOOT FULLY PRESSED ON THE BRAKE PEDAL AND THE “HOLD” SIGN WAS SHOWING ON THE INSTRUMENT PANEL SCREEN. APPROXIMATELY 2 MINUTES LATER, SHE RELEASED THE BRAKE PEDAL. BUT BEFORE SHE COULD PRESS THE GAS PEDAL, THE CAR SUDDENLY MOVED FORWARD BY ITSELF AT ALMOST FULL ACCELERATION. MY WIFE IMMEDIATELY ATTEMPTED TO STOP THE CAR BY PRESSING THE BRAKE PEDAL IN FULL. THE CAR SLOWED DOWN, BUT DID NOT FULLY STOP AND KEPT MOVING FORWARD UNTIL IT HIT THE CAR IN FRONT OF IT.

18. July 7, 2017 **NHTSA ID NUMBER: 11003716**

MY TESLA MODEL X 2016 ACCELERATED ON ITS OWN AFTER I COME TO A COMPLETE STOP AT A PARKING LOT.

19. January 28, 2018 **NHTSA ID NUMBER: 11065563**

AT OUR DRIVEWAY, COMING BACK FROM SHOPPING, SUDDENLY THE CAR TOOK OFF BY ITSELF. IT ACCELERATED TREMENDOUSLY WITH THE SPEED WHICH WAS FELT AROUND 65-80 M/HR, HITTING OUR HEAVY GARAGE DOOR, WHICH WAS CLOSED AT THE TIME.

20. November 23, 2017 **NHTSA ID NUMBER: 11048161**

WE WERE IN A PARKING LOT. ... OUR CAR WAS IN STATIONARY POSITION. WE WERE TRYING TO FIGURE OUT WHERE TO PARK. DURING THIS TIME, OUR MODEL X, TOOK OFF WITH UNINTENDED ACCELERATION AND WE COULD NOT CONTROL THE CAR. IT WAS INSTANTANEOUS.

21. December 3, 2018 **NHTSA ID NUMBER: 11155579**

CAR WAS STOPPED PRIOR TO ENTERING CAR GARAGE. CAR SUDDENLY REVERSED THEN SPED UP AUTONOMOUSLY AND CRASHED INTO THE HOME.

22. June 18, 2018 **NHTSA ID NUMBER: 11102347**

WHILE APPROACHING A RED LIGHT, THE SPEED INCREASED AND THE VEHICLE FAILED TO RESPOND WHEN THE BRAKE PEDAL WAS DEPRESSED. THE VEHICLE DROVE THROUGH THE TRAFFIC LIGHT AND CRASHED.

23. December 15, 2019 **NHTSA ID NUMBER: 11289172**

USING THE SELF-PARK SYSTEM, FROM A STATIONARY POSITION AND PRESSING THE TOUCH SCREEN PROMPTS TO USE THE SELF-PARK, AND HAVING HANDS AND FEET AWAY FROM THE GAS, BRAKE AND STEERING WHEEL, AND PARKING BETWEEN TWO CARS, THE CAR ACCELERATED BACKWARD ON ITS OWN AND I HAD TO SLAM MY FOOT ON THE BRAKE TO STOP IT BUT IT STILL HIT A POLE GOING IN REVERSE.

24. November 26, 2018 **NHTSA ID NUMBER: 11154132**

TESLA MODEL 3 (2018) PROCEEDED TO ACCELERATE WHILE BRAKE PEDAL WAS DEPRESSED GOING THROUGH AN INTERSECTION. ... THE VEHICLE FAILED TO RESPOND TO PEDAL INPUT. ... AUTOPILOT WAS ENGAGED PRIOR TO CRASH.

25. November 30, 2019 **NHTSA ID NUMBER: 11282993**

WE WERE DRIVING OUR 5-MONTH-OLD TESLA MODEL 3. WE WERE COMING TO A STOP AT A STOPLIGHT IN HEAVY TRAFFIC, WHEN SUDDENLY THE CAR ACCELERATED ON ITS OWN. MY HUSBAND HAD TO BRAKE SUDDENLY TO PREVENT RUNNING INTO ANOTHER CAR.

26. October 8, 2019 **NHTSA ID NUMBER: 11267131**

MY WIFE WAS TRYING TO PARK THE CAR IN OUR GARAGE WHEN THE CAR SUDDENLY SPED UP AND HIT OUR INNER GARAGE WALL. IT THEN REVERSED BACK AND HIT THE WALL A SECOND TIME. THEN IT AUTOMATICALLY REVERSED AND PARKED ON THE NEIGHBOR'S DRIVEWAY.

27. May 10, 2019 **NHTSA ID NUMBER: 11206931**

I WAS STOPPED AT A RED LIGHT, SECOND IN LINE. MY CAR LUNGED BACKWARDS HITTING THE CAR BEHIND ME. I HAD DONE NOTHING TO MOVE THE VEHICLE.

### **C. Incidents starting at high speed**

1. November 5, 2019 **NHTSA ID NUMBER: 11278322**

WHILE DRIVING 65-70 MPH FOR THIRTY MINUTES WITH THE AUTO PILOT ENGAGED, THE VEHICLE SPONTANEOUSLY ACCELERATED WITHOUT WARNING.

2. June 15, 2017 **NHTSA ID NUMBER: 10995382**

GOING THE SPEED LIMIT, & RELEASED THE ACCELERATOR SO THAT "ENGINE BRAKING" WOULD SLOW THE CAR. BUT I WAS SLOWING DOWN FASTER THAN NECESSARY WITH ~100 YARDS REMAINING TO REACH THE INTERSECTION. I LIGHTLY PRESSED THE ACCELERATOR TO STOP ENGINE BRAKING BRIEFLY, THEN RELEASED THE ACCELERATOR TO REINSTATE "ENGINE BRAKING". INSTEAD OF SLOWING, MY CAR BEGAN TO WILDLY ACCELERATE. ... ANOTHER PIECE OF INFORMATION: 2 TIMES WITHIN THE PRIOR WEEK, WHEN GETTING INTO MY CAR (AWAY FROM MY HOME), THE CAR INDICATED "PREPARING TO DRIVE" OR SOMETHING TO THAT EFFECT (NOT A MESSAGE I NORMALLY SEE), THE MESSAGE PERSISTED, SO BOTH TIMES I HAD TO REBOOT THE COMPUTER SYSTEM, TO MAKE THE CAR DRIVE-ABLE. COULD THIS BE AT ALL RELATED TO THE ACCIDENT ON JUNE 9TH?

3. August 7, 2018 **NHTSA ID NUMBER: 11118315**

THE CAR AUTO ACCELERATED ON A SURFACE STREET AND CRASHED.

4. November 30, 2019 **NHTSA ID NUMBER: 11282996**

ON 11-27-19, OUT TESLA MODEL 3 WHICH IS 5 MONTHS OLD, SUDDENLY ACCELERATED IN TRAFFIC. MY HUSBAND WAS DRIVING ABOUT 20 MILES AN HOUR AT THE TIME. THIS ALSO OCCURRED ON 11-29-19,

5. October 1, 2019 **NHTSA ID NUMBER: 11265452**

AS VEHICLE WAS TRAVELING ON THE HIGHWAY, THE DRIVER REPORTEDLY TRIED TO SLOW THE VEHICLE AS IT APPROACHED STOPPED/SLOWED TRAFFIC. VEHICLE DID NOT RESPOND AND DRIVER WAS NOT ABLE TO SLOW IT BEFORE IT CRASHED INTO STOPPED TRAFFIC.

## References

- 
- <sup>1</sup> The Tesla Team, “There is no “unintended acceleration” in Tesla vehicles”, January 20, 2020 [https://www.tesla.com/es\\_ES/blog/no-unintended-acceleration-tesla-vehicles?redirect=no](https://www.tesla.com/es_ES/blog/no-unintended-acceleration-tesla-vehicles?redirect=no)
- <sup>2</sup> Steve Hanley, “Tesla Responds to “Sudden Unintended Acceleration” Petition to NHTSA”, Jan 21, 2020. <https://cleantechnica.com/2020/01/21/tesla-responds-to-sudden-unintended-acceleration-petition-to-nhtsa/>
- <sup>3</sup> Nathaniel Michaluk, “One Pedal Driving – Rapid Feature Development with Simulink”, Mathworks Automotive Conference, May 9, 2017.
- <sup>4</sup> J.J. Van Boekel, I.J.M Besselink, and H. Nijmeier, “Design and Realization of a One-Pedal Driving Algorithm for the TU/e Lupo EL”, World Electric Vehicle Journal, Vol 7, Kintex, Korea, May 3-6, 2015.
- <sup>5</sup> J. Wang, “Battery Electric Vehicle Energy Consumption Testing and Prediction: A Practical Case Study”, PhD Thesis, Eindhoven University of Technology, Eindhoven, the Netherlands, 2016
- <sup>6</sup> Dongbin Lu, Minggao Ouyang, Jing Gu, and Jianqiu Li, “Instantaneous Optimal Regenerative Braking Control for a Permanent Magnet Synchronous Motor in a Four-Wheel Drive Electric Vehicle”, Proceedings of the Institution of Mechanical Engineers, Part D; Journal of Automobile Engineering, published online February 2014.
- <sup>7</sup> Xiaofeng Ding, Jiawei Cheng, and Feida Chen, “Impact of Silicon Carbide Devices on the Powertrain Systems in Electric Vehicles”, in Energies 2017, edited by Rui Xiong, 10(4), p533. <https://doi.org/10.3390/en10040533>, found at <https://www.mdpi.com/1996-1073/10/4/533>
- <sup>8</sup> EPA Vehicle Chassis Dynamometer Driving Schedules (DDS), Vehicle and Fuel Emissions Testing, United States Environmental Protection Agency, <https://www.epa.gov/vehicle-and-fuel-emissions-testing/dynamometer-drive-schedules>
- <sup>9</sup> Wugz, “Model 3 AWD tested from 100-0 km/h – ROLL Mode vs. HOLD Mode”, Reddit, [https://www.reddit.com/r/teslamotors/comments/dv671z/model\\_3\\_awd\\_tested\\_from\\_100\\_kmh\\_roll\\_mode\\_vs/](https://www.reddit.com/r/teslamotors/comments/dv671z/model_3_awd_tested_from_100_kmh_roll_mode_vs/)
- <sup>10</sup> Ibid, Note 7.
- <sup>11</sup> Rayad Kubiasi, “Adaptive Regenerative Braking in Electric Vehicles”, Dissertation for Doctors der Ingenieur wissenschaften (Dr. –Ing), Karlsruher Institut für Technologie (KIT), December 1, 2018.
- <sup>12</sup> Selim Oleksowicz, Mariusz Ruta, Keith Brunham, Eddie Curry, and Hector Garces, “Legal, Safety, and Practical Regenerative Braking Control Challenges”, Measurement and Control, Vol 46, No. 9, November 2013.
- <sup>13</sup> This figure is found in the following ten US Tesla patents and patent applications: US7739005B1, US7742852, US7747363, US9162586B2, US2014/0257613A1, US2016/0009197A1, US8453770B2, US8761985B2, US2010/0222953, US2013/0241445. All have incorrect figures showing an addition operation instead of a modulation operation. The last four patents show a VSC input to the Vehicle Torque Command Generation Function.
- <sup>14</sup> Ibid, Note 10.
- <sup>15</sup> Bosch iBooster, EN | IAA 2013, <https://www.youtube.com/watch?v=f8RsWGs7Lso&feature=youtu.be>
- <sup>16</sup> Robert Bosch GmbH, “iBooster – Vacuum Independent Electro-Mechanical Brake Booster”, product spec sheet 292000P12J-C/CCA-201308-En, 2013.
- <sup>17</sup> <https://www.bosch-mobility-solutions.com/en/products-and-services/passenger-cars-and-light-commercial-vehicles/driving-safety-systems/brake-booster/ibooster/>
- <sup>18</sup> Ibid, Note 14.
- <sup>19</sup> <https://www.bosch-mobility-solutions.com/en/products-and-services/passenger-cars-and-light-commercial-vehicles/driving-safety-systems/regenerative-braking-systems/esp-hev/>
- <sup>20</sup> <http://www.myshared.ru/slide/885225/>

- 
- <sup>21</sup> US patent 9315182B2, “*Braking System*”, by Ryan A. Kuhlman, assigned to Robert Bosch GmbH, April 19, 2016.
- <sup>22</sup> US patent 9586486, “*Control Unit for a Recuperative Brake System of a Vehicle and Method for Braking a Vehicle*”, by Michael Kunz and Stefan Strengert, assigned to Robert Bosch GmbH, Mar 7, 2017.
- <sup>23</sup> Max Boerboom, “*Electric Vehicle Blended Braking Maximizing Energy Recovery While Maintaining Vehicle Stability and Manueverability*”, Master’s Thesis 2012:01, Chalmers University of Technology, Goteborg, Sweden, Jan 2012.
- <sup>24</sup> US patent 6535809B1, “*Vehicle Engine Torque Control with Engine Drag Control Mode*”, by Keith Beyer, Eric, Krueger, Vincent Marchese, Todd Brown, and Alan Lustre, assigned to Delphi Techologies, Inc; March 18, 2003.
- <sup>25</sup> German patent DE10238224B4. “*Curve-Dependent Engine Drag Torque Control*”, by Thomas Sauter, assigned to Robert Bosch GmbH, October 16, 2003.
- <sup>26</sup> US patent 6535809B1, “*Vehicle Engine Torque Control with Engine Drag Control Mode*”, by Keith Beyer, Eric, Krueger, Vincent Marchese, Todd Brown, and Alan Lustre, assigned to Delphi Techologies, Inc; March 18, 2003.
- <sup>27</sup> US patent application 2003/0221889A1, “*Curve-Dependent Engine Drag Torque Control*”, Thomas Sauter, March 27, 2003.
- <sup>28</sup> US patent 7681960B2, “*Method and System for Improving the Driving Behavior of a Vehicle*”, by Peter Wanke, Torsten Herrman, Mario Roszyk, Thorsten Wickenhofer, Matthias Pank, and Jochen Konanz, assigned to Continental Teves AG & Co oHG, March 23,
- <sup>29</sup>United Nations Economic Commission for Europe (UN/ECE) Regulation No. 13-H (2017) with Annexes 1 to 9, “*Technical Requirements, Test Methods, and Limit Values for the Braking Systems of Passenger Cars and Light Commercial Vehicles*”, par 2.17.2.
- <sup>30</sup> United Nations Economic Commission for Europe of the (UN/ECE) Regulation No 140 “*Uniform provisions concerning the approval of passenger cars with regard to Electronic Stability Control (ESC) Systems*”, par 6.2.2, 6.2.4.
- <sup>31</sup> Ibid, Note 22, 2018/1592, par 6.2.3.
- <sup>32</sup> Ibid, Note 22, 2018/1592, par 9.10.1.
- <sup>33</sup> United Nations Economic Commission for Europe (UN/ECE) Regulation No. 13-H (2017) with Annexes 1 to 9, “*Technical Requirements, Test Methods, and Limit Values for the Braking Systems of Passenger Cars and Light Commercial Vehicles*”, par 5.2.22.4.
- <sup>34</sup> USA regulation 49 CFR § 571.126 Federal Standard No. 126; “*Electronic stability control systems for light vehicles*”, par S5.1.3.
- <sup>35</sup> “*ID4EV -- Intelligent Dynamics for Electric Vehicles*”, a study on the requirements and specifications for electric vehicles derived from user needs and SOTA analysis performed under European research project co-funded by the European Commission under the 7th Framework programme, p 33.
- <sup>36</sup> Ibid, Note 27, p77.
- <sup>37</sup> Ibid, Note 27, p77, par j.
- <sup>38</sup> Ibid, Note 27, p77, par j.
- <sup>39</sup> “*Investigation Into Regenerative Braking Systems*” by B. J. Robinson, C. Visvikis, T. Gibson, and I. Knight of the Transport Research Laboratory, published project report No. PPR582 for the Department for Transport, Transport Technology and Standards, United Kingdom, 2011, p10.
- <sup>40</sup> Ibid, Note 31, p12.
- <sup>41</sup> [https://forums.tesla.com/de\\_CH/node/87902](https://forums.tesla.com/de_CH/node/87902). This is the German Tesla forum.
- <sup>42</sup> <https://teslamotorsclub.com/tmc/threads/another-sudden-acceleration.157549/>
- <sup>43</sup> <https://teslamotorsclub.com/tmc/threads/regenerative-braking-safety-issue.52053/page-2>
- <sup>44</sup> <https://fordfusionhybridforum.com/topic/9866-regen-braking-issue-when-turning/page/3/>
- <sup>45</sup> <https://teslamotorsclub.com/tmc/threads/reduced-regen-with-lateral-gs.115479/>

---

<sup>46</sup><https://www.courtlistener.com/recap/gov.uscourts.cacd.770392/gov.uscourts.cacd.770392.1.o.pdf>

<sup>47</sup><https://insideevs.com/news/364540/video-bmw-i3-crash-building/>

<sup>48</sup>[https://www.facebook.com/permalink.php?story\\_fbid=1928733057185174&id=239295872795576](https://www.facebook.com/permalink.php?story_fbid=1928733057185174&id=239295872795576)

<sup>49</sup><https://www.bmwblog.com/2014/06/23/living-bmw-i3-2000-miles-dislikes/>

<sup>50</sup><https://insideevs.com/reviews/336237/bmw-i3-sport-one-month-review/>

<sup>51</sup><https://www.autosafety.org/dr-ronald-a-belts-sudden-acceleration-papers/>

<sup>52</sup><https://autotechreview.com/cover-stories/electromechanical-brake-booster-for-all-drive-concepts-automated-driving-2>

<sup>53</sup><https://www.greencarcongress.com/2018/05/20180522-cr.html>

<sup>54</sup><https://www.forbes.com/sites/samabuelsamid/2018/05/30/rapid-tesla-software-updates-are-great-but-hide-more-fundamental-problems/#2d5802e657de>

<sup>55</sup><http://www.news.com.au/national/hyundai-models-in-voluntary-recall-over-faulty-brake-light-switch/story-fncynjr2-1226591850472>

<sup>56</sup><https://www.edmunds.com/car-news/2009-11-hyundai-accent-recalled-for-brake-switch-problem.html>

<sup>57</sup><https://www.goauto.com.au/news/kia/kia-acts-on-faulty-brake-switch/2013-09-26/21715.html>

<sup>58</sup><https://www.foxbusiness.com/features/subaru-announces-it-biggest-recall-ever-over-brake-lights>

<sup>59</sup><https://www.goauto.com.au/news/kia/kia-acts-on-faulty-brake-switch/2013-09-26/21715.html>

<sup>60</sup> NHTSA Campaign Number: 19V418000, <https://www.citybike.com/news-clues-rumors/suzuki-gsx250r-recall-brake-light-failure/>

<sup>61</sup><http://pressroom.toyota.com/releases/customer+faqs+toyota+venza+camry+stop+lamp+switch+recall.htm>

<sup>62</sup><https://www.consumeraffairs.com/news/gm-recalls-nearly-25-million-vehicles-with-electrical-problems-051614.html>

<sup>63</sup>[http://www.huffingtonpost.com/2014/05/29/gm-recall-delay-documents\\_n\\_5412979.html](http://www.huffingtonpost.com/2014/05/29/gm-recall-delay-documents_n_5412979.html)

<sup>64</sup><http://z71tahoe-suburban.com/iboard/lofiversion/index.php?t38495.html>

<sup>65</sup><https://www.equipmentworld.com/ford-issues-recalls-for-f-150-due-to-brake-light-and-seat-issues/>

<sup>66</sup><http://www.f150forum.com/f10/brake-light-delay-153363/>

<sup>67</sup><http://www.bimmerforums.com/forum/showthread.php?1154981-Brake-Light-Delay>

<sup>68</sup><https://teslamotorsclub.com/tmc/threads/brake-lights-not-coming-on-w-proof.122555/#post-2872074>

<sup>69</sup><https://www.courtlistener.com/recap/gov.uscourts.cacd.770392/gov.uscourts.cacd.770392.1.o.pdf>